

Washer-Extractors

Cabinet Hardmount

Refer to Page 6 for Model Identification

CE

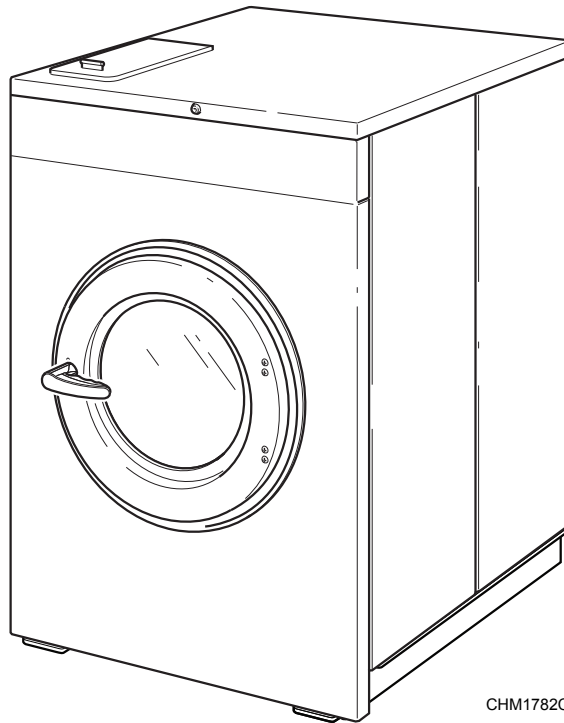

CHM1782C

Installation/Operation/Maintenance

Original Instructions

Keep These Instructions for Future Reference.

Alliance
Laundry Systems

www.alliancelaundry.com

Part No. F8429301ENR6
December 2012

Table of Contents

Safety Information	3
Explanation of Safety Messages.....	3
Important Safety Instructions	3
Safety Decals	5
Operator Safety.....	5
Introduction	6
Model Identification	6
Delivery Inspection.....	8
Nameplate Location.....	8
Replacement Parts	9
Customer Service.....	9
Specifications and Dimensions	10
Mounting Bolt Hole Locations – 20, 30, 40 and 60 Pound Models.....	17
Mounting Bolt Hole Location – 80 and 100 Pound Models.....	21
Mounting Bolt Hole Locations – 125 Pound Models.....	23
Floor Mounting Layout – 20, 30, 40 and 60 Pound Models.....	24
Floor Layout – 80 and 100 Pound Models	26
Installation	29
Pallet Jack Cover Plate Removal (80 and 100 Pound Models Only).....	29
Single Machine Foundation Requirements.....	29
Machine Installation with Existing Floor	29
Elevated Pad Installation with Existing Floor	30
Elevated Base Frame Installation with Existing Floor	30
New Foundation.....	30
Isolated Pad Installation.....	30
Machine Foundation and Pad Installation	31
Single Machine Installation – 20 and 30 Pound Models (F and V-speed).....	33
Single Machine Installation – 40 and 60 Pound Models (F-speed).....	34
Single Machine Installation – 40 and 60 Pound Models (V-speed).....	35
Single Machine Installation – 80 and 100 Pound Models (F-speed).....	36
Single Machine Installation – 80 and 100 Pound Models (V-speed).....	37
Single Machine Installation – 125 Pound Models (V-speed).....	38
Machine Mounting and Grouting.....	39
Drain Connection.....	42
Water Connection Requirements	44
Electrical Installation Requirements.....	45
Input Power Conditioning.....	46
Input Voltage Requirements	47
Circuit Breakers and Quick Disconnects.....	47

© Copyright 2012, Alliance Laundry Systems LLC

All rights reserved. No part of the contents of this book may be reproduced or transmitted in any form or by any means without the expressed written consent of the publisher.

Connection Specifications	47
Single-Phase Connections.....	47
Three-Phase Connections.....	48
Grounding	48
Phase Adder	48
Thermal Overload Protector	48
Electrical Specifications.....	49
Steam Requirements (Steam Heat Option Only).....	57
Supply Dispensing.....	57
External Supplies	58
Chemical Injection Using Internal 24VAC	
Control Transformer.....	58
Chemical injection Using External AC Power Source	60
External Supply Signals.....	61
Connection of External Liquid Supplies.....	62
Start Up	63
Pallet Jack cover Plate Installation (80 and 100 Pound	
Models Only).....	63
Basket Rotation.....	63
Operation	64
Operating Instructions	64
Maintenance	66
Daily	66
Beginning of Day	66
End of Day	66
Weekly.....	66
Monthly.....	67
Quarterly	68
Care of Stainless Steel	69
Disposal of Unit	70

Safety Information

Explanation of Safety Messages

Precautionary statements (“DANGER,” “WARNING,” and “CAUTION”), followed by specific instructions, are found in this manual and on machine decals. These precautions are intended for the personal safety of the operator, user, servicer, and those maintaining the machine.

	DANGER
DANGER indicates an imminently hazardous situation that, if not avoided, will cause severe personal injury or death.	

	WARNING
WARNING indicates a hazardous situation that, if not avoided, could cause severe personal injury or death.	

	CAUTION
CAUTION indicates a hazardous situation that, if not avoided, may cause minor or moderate personal injury or property damage.	

Additional precautionary statements (“IMPORTANT” and “NOTE”) are followed by specific instructions.

IMPORTANT: The word “IMPORTANT” is used to inform the reader of specific procedures where minor machine damage will occur if the procedure is not followed.

NOTE: The word “NOTE” is used to communicate installation, operation, maintenance or servicing information that is important but not hazard related.

Important Safety Instructions

	WARNING
To reduce the risk of fire, electric shock, serious injury or death to persons when using your washer, follow these basic precautions:	
W023	

1. Read all instructions before using the washer.
2. Install the washer according to the INSTALLATION instructions. Refer to the GROUNDING instructions in the INSTALLATION manual for the proper grounding of the washer. All connections for water, drain, electrical power and grounding must comply with local codes and be made by licensed personnel when required. It is recommended that the machine be installed by qualified technicians.
3. Do not install or store the washer where it will be exposed to water and/or weather.
4. To prevent fire and explosion, keep the area around machine free from flammable and combustible products. Do not add the following substances or textiles containing traces of the following substances to the wash water: gasoline, kerosene, waxes, cooking oils, vegetable oils, machine oils, dry-cleaning solvents, flammable chemicals, thinners, or other flammable or explosive substances. These substances give off vapors that could ignite, explode or cause the fabric to catch fire by itself.
5. Under certain conditions, hydrogen gas may be produced in a hot water system that has not been used for two weeks or more. HYDROGEN GAS IS EXPLOSIVE. If the hot water system has not been used for such a period, before using a washing machine or combination washer-dryer, turn on all hot water faucets and let the water flow from each for several minutes. This will release any accumulated hydrogen gas. The gas is flammable, do not smoke or use an open flame during this time.
6. To reduce the risk of an electric shock or fire, DO NOT use an extension cord or an adapter to connect the washer to the electrical power source.

Safety Information

7. Do not allow children to play on or in the washer. Close supervision of children is necessary when the washer is used near children. This appliance is not intended for use by young children or infirm persons without supervision. Young children should be supervised to ensure that they do not play with the appliance. This is a safety rule for all appliances.
8. DO NOT reach and/or climb into the tub or onto the washer, ESPECIALLY if the wash drum is moving. This is an imminently hazardous situation that, if not avoided, will cause severe personal injury or death.
9. Never operate the washer with any guards, panels and/or parts removed or broken. DO NOT bypass any safety devices or tamper with the controls.
10. Use washer only for its intended purpose, washing textiles. Never wash machine parts or automotive parts in the machine. This could result in serious damage to the basket or tub.
11. Use only low-sudsing, no-foaming types of commercial detergent. Be aware that hazardous chemicals may be present. Wear hand and eye protection when adding detergents and chemicals. Always read and follow manufacturer's instructions on packages of laundry and cleaning aids. Heed all warnings or precautions. To reduce the risk of poisoning or chemical burns, keep them out of the reach of children at all times (preferably in a locked cabinet).
12. Do not use fabric softeners or products to eliminate static unless recommended by the manufacturer of the fabric softener or product.
13. Always follow the fabric care instructions supplied by the textile manufacturer.
14. Loading door MUST BE CLOSED any time the washer is to fill, tumble or spin. DO NOT bypass the loading door switch by permitting the washer to operate with the loading door open. Do not attempt to open the door until the washer has drained and all moving parts have stopped.
15. Be aware that hot water is used to flush the supply dispenser. Avoid opening the dispenser lid while the machine is running.
16. Do not attach anything to the supply dispenser's nozzles, if applicable. The air gap must be maintained.
17. Do not operate the machine without the water reuse plug or water reuse system in place, if applicable.
18. Be sure water connections have a shut-off valve and that fill hose connections are tight. CLOSE the shut-off valves at the end of each wash day.
19. Keep washer in good condition. Bumping or dropping the washer can damage safety features. If this occurs, have washer checked by a qualified service person.
20. DANGER: Before inspecting or servicing machine, power supply must be turned OFF. The servicer needs to wait for at least 3 minutes after turning the power OFF and needs to check for residual voltage with a voltage meter. The inverter capacitor or EMC filter remains charged with high voltage for some time after powering OFF. This is an imminently hazardous situation that, if not avoided, will cause severe personal injury or death.
21. Do not repair or replace any part of the washer, or attempt any servicing unless specifically recommended in the user-maintenance instructions or in published user-repair instructions that the user understands and has the skills to carry out. ALWAYS disconnect the washer from electrical, power and water supplies before attempting any service.
22. Disconnect the power cord by grasping the plug, not the cord. Replace worn power cords and/or loose plugs. If the supply cord is damaged, it must be replaced by a special cord or assembly available from the service agent.
23. Before the washer is removed from service or discarded, remove the door to the washing compartment.
24. Failure to install, maintain, and/or operate this washer according to the manufacturer's instructions may result in conditions which can produce bodily injury and/or property damage.

NOTE: The WARNINGS and IMPORTANT SAFETY INSTRUCTIONS appearing in this manual are not meant to cover all possible conditions and situations that may occur. Common sense, caution and care must be exercised when installing, maintaining, or operating the washer.

Any problems or conditions not understood should be reported to the dealer, distributor, service agent or the manufacturer.

	WARNING
<p>This machine must be installed, adjusted, and serviced by qualified electrical maintenance personnel familiar with the construction and operation of this type of machinery. They must also be familiar with the potential hazards involved. Failure to observe this warning may result in personal injury and/or equipment damage, and may void the warranty.</p>	
SW004	

IMPORTANT: Ensure that the recommended clearances for inspection and maintenance are provided. Never allow the inspection and maintenance space to be blocked.

	WARNING
<p>Never touch internal or external steam pipes, connections, or components. These surfaces can be extremely hot and will cause severe burns. The steam must be turned off and the pipe, connections, and components allowed to cool before the pipe can be touched.</p>	
SW014	

Safety Decals

Safety decals appear at crucial locations on the machine. Failure to maintain legible safety decals could result in injury to the operator or service technician.

Use manufacturer-authorized spare parts to avoid safety hazards.

Operator Safety

	WARNING
<p>NEVER insert hands or objects into basket until it has completely stopped. Doing so could result in serious injury.</p>	
SW012	

The following maintenance checks must be performed daily:

1. Verify that all warning labels are present and legible, replace as necessary.
2. Check door interlock before starting operation of the machine:
 - a. Attempt to start the machine with the door open. The machine should not start.
 - b. Close the door without locking it and start the machine. The machine should not start.
 - c. Attempt to open the door while a cycle is in progress. The door should not open.

If the door lock and interlock are not functioning properly, disconnect power and call a service technician.
3. Do not attempt to operate the machine if any of the following conditions are present:
 - a. The door does not remain securely locked during the entire cycle.
 - b. Excessively high water level is evident.
 - c. Machine is not connected to a properly grounded circuit.

	WARNING
<p>Operating the machine with severe out-of-balance loads could result in personal injury and serious equipment damage.</p>	
W728	

Introduction

Model Identification

Information in this manual is applicable to these models:

Model						
20 POUND	HCD020LDV	HCN020KEF	SCN020JCF	SCN020WCV	SCU020JLV	SCU020WEV
	HCL020HDF	HCN020KEV	SCN020JCV	SCN020WDV	SCU020JXF	SCU020WXV
	HCL020HNF	HCN020KYF	SCN020JEF	SCN020WYF	SCU020JXV	SCU020WYV
	HCL020HNV	HCN020KYV	SCN020JXF	SCN020WYV	SCU020JYF	UCL020GNV
	HCL020KDF	HCU020HNV	SCN020JYF	SCU020GNV	SCU020JYV	UCL020HNF
	HCL020KDV	HCU020KLF	SCN020JYV	SCU020HNF	SCU020KNF	UCL020HNV
	HCN020HCF	SCL020HNV	SCN020KNF	SCU020JCF	SCU020LCV	UCN020GNV
	HCN020HNF	SCL020JCF	SCN020KNV	SCU020JCV	SCU020LDV	UCN020HNF
	HCN020HNV	SCL070JXF	SCN020LCF	SCU020JDF	SCU020LEV	UCN020HNV
	HCN020HYF	SCL020LDF	SCN020LCV	SCU020JDV	SCU020LXV	UCU020GNV
	HCN020KCF	SCL020LXF	SCN020LYF	SCU020JEF	SCU020LYV	UCU020HNF
	HCN020KCV	SCL020WXF	SCN020LYV	SCU020JEV	SCU020WCV	UCU020HNV
	HCN020KDV	SCN020HNV	SCN020WCF	SCU020JLF	SCU020WDV	
30 POUND	HCD030LDV	HCN030KEF	SCL030JEF	SCN030LCV	SCU030JEF	SCU030WXV
	HCL030HDF	HCN030KYF	SCL030JXF	SCN030LXF	SCU030JEV	SCU030WYV
	HCL030HEF	HCN030KYV	SCL030KNF	SCN030LYF	SCU030JLF	SCZ030GNF
	HCL030HNF	HCU030GNV	SCL030KNV	SCN030LYV	SCU030JLV	UCL030GNV
	HCL030HNV	HCU030HNF	SCL030LEV	SCN030WCF	SCU030JXF	UCL030HNF
	HCL030KDF	HCU030HNV	SCL030WXF	SCN030WCV	SCU030JXV	UCL030HNV
	HCL030KDV	HCU030KCF	SCN030GNV	SCN030WDV	SCU030JYF	UCL030KNF
	HCN030GNV	HCU030KCV	SCN030HNF	SCN030WEV	SCU030JYV	UCL030KNV
	HCN030HCF	HCU030KEV	SCN030HNV	SCN030WLV	SCU030KNF	UCN030GNV
	HCN030HDF	HCU030KYF	SCN030JCF	SCN030WYF	SCU030LCV	UCN030HNF
	HCN030HNF	HCU030KYV	SCN030JCV	SCN030WYV	SCU030LDV	UCN030HNV
	HCN030HNV	SCL030GNV	SCN030JEF	SCU030GNV	SCU030LEV	UCN030KNF
	HCN030HYF	SCL030HNF	SCN030JXF	SCU030HNF	SCU030LXV	UCU030GNV
	HCN030KCF	SCL030HNV	SCN030JYF	SCU030JCF	SCU030LYV	UCU030HNF
	HCN030KCV	SCL030LXF	SCN030JYV	SCU030JCV	SCU030WCV	UCU030HNV
	HCN030KDF	SCL030JCF	SCN030KNF	SCU030JDF	SCU030WDV	
	HCN030KDV	SCL030JDF	SCN030LCF	SCU030JDV	SCU030WEV	
40 POUND	HCL040GNV	HCN040KYV	SCL040KNF	SCN040LDV	SCU040JLV	UCL040GNV
	HCL040HDF	HCU040GNV	SCL040KNV	SCN040LYF	SCU040JXF	UCL040HNF
	HCL040HNF	HCU040HNF	SCL040LXF	SCN040LYV	SCU040JXV	UCL040HNV
	HCL040HNV	HCU040HNV	SCL040WXF	SCN040WCF	SCU040JYF	UCL040KNF
	HCL040KDF	HCU040KCF	SCN040GNV	SCN040WCV	SCU040JYV	UCL040KNV
	HCL040KDV	HCU040KCV	SCN040HNF	SCN040WDV	SCU040KNF	UCN040GNF
	HCN040GNV	HCU040KEV	SCN040HNV	SCN040WYF	SCU040KNV	UCN040GNV
	HCN040HCF	HCU040KYF	SCN040JCF	SCN040WYV	SCU040LCV	UCN040HNF
	HCN040HNF	HCU040KYV	SCN040JCV	SCU040GNV	SCU040LDV	UCN040HNV
	HCN040HYF	SCL040GNV	SCN040JEF	SCU040HNF	SCU040LEV	UCN040KNF
	HCN040KCF	SCL040HNF	SCN040JYF	SCU040JCF	SCU040LXV	UCN040KNV
	HCN040KCV	SCL040HNV	SCN040JYV	SCU040JCV	SCU040LYV	UCU040GNV
	HCN040KDF	SCL040JCF	SCN040KNF	SCU040JDF	SCU040WCV	UCU040HNF
	HCN040KDV	SCL040JDF	SCN040KNV	SCU040JDV	SCU040WDV	UCU040HNV
	HCN040KEF	SCL040JEF	SCN040LCF	SCU040JEF	SCU040WEV	UCU040KNV
	HCN040KEV	SCL040JXF	SCN040LCV	SCU040JEV	SCU040WXV	
	HCN040KYF	SCL040JXV	SCN040LDF	SCU040JLF	SCU040WYV	

(Continued)

(Continued)

60 POUND	HCL060GNV	HCN060KEF	SCL060JXF	SCN060LDV	SCU060JEV	SCU060WEV
	HCL060HCF	HCN060KEV	SCL060KNV	SCN060LYF	SCU060JLF	SCU060WXV
	HCL060HNF	HCN060KYF	SCN060GNF	SCN060LYV	SCU060JLV	SCU060WYV
	HCL060HNV	HCN060KYV	SCN060GNV	SCN060WCF	SCU060JXF	UCL060GNV
	HCL060KDF	HCU060GNV	SCN060HNV	SCN060WCV	SCU060JXV	UCL060HNF
	HCL060KDV	HCU060HNF	SCN060LDF	SCN060WDV	SCU060JYF	UCL060HNV
	HCN060GNV	HCU060HNV	SCN060JCF	SCN060WEV	SCU060JYV	UCL060KNV
	HCN060HCF	HCU060KCF	SCN060JCV	SCN060WYF	SCU060KNF	UCN060GNV
	HCN060HDF	HCU060KCV	SCN060JDF	SCN060WYV	SCU060KNV	UCN060HNF
	HCN060HNF	HCU060KEV	SCN060JEF	SCU060GNV	SCU060LCV	UCN060HNV
	HCN060HNV	HCU060KYF	SCN060JYF	SCU060HNF	SCU060LDV	UCN060KNF
	HCN060HYF	HCU060KYV	SCN060JYV	SCU060JCF	SCU060LEV	UCN060KNV
	HCN060KCF	SCL060GNV	SCN060KNF	SCU060JCV	SCU060LXV	UCU060GNV
	HCN060KCV	SCL060HNF	SCN060KNV	SCU060JDF	SCU060LYV	UCU060HNF
	HCN060KDF	SCL060HNV	SCN060LCF	SCU060JDV	SCU060WCV	UCU060HNV
HCN060KDV	SCL060JCF	SCN060LCV	SCU060JEF	SCU060WDV	UCU060KNV	
80 POUND	HCD080LDF	HCN080KCF	SCD080LDV	SCN080WCF	SCU080JXF	UCL080GNF
	HCD080LDV	HCN080KCV	SCL080GNF	SCN080WCV	SCU080JXV	UCL080HNF
	HCL080GNF	HCN080KDF	SCL080HNF	SCN080WDV	SCU080JYF	UCL080KNV
	HCL080HNF	HCN080KDV	SCL080KNV	SCN080WYF	SCU080JYV	UCN080GNF
	HCL080HNV	HCN080KEV	SCN080GNF	SCN080WYV	SCU080KNV	UCN080HNF
	HCL080KDF	HCN080KYF	SCN080HNF	SCU080GNF	SCU080LCV	UCN080HNV
	HCL080KDV	HCN080KYV	SCN080JCF	SCU080HNF	SCU080LDV	UCN080KNF
	HCN080GNF	HCU080GNF	SCN080JCV	SCU080JCF	SCU080LEV	UCN080KNV
	HCN080HCF	HCU080HCF	SCN080JDF	SCU080JCV	SCU080LXV	UCU080GNF
	HCN080HCV	HCU080HNF	SCN080JYF	SCU080JDF	SCU080LYV	UCU080HNF
	HCN080HDF	HCU080HXF	SCN080JYV	SCU080JDV	SCU080WCV	UCU080KNV
	HCN080HNF	HCU080KCF	SCN080KNV	SCU080JEF	SCU080WDV	
	HCN080HNV	HCU080KCV	SCN080LCV	SCU080JEV	SCU080WEV	
	HCN080HYF	HCU080KYF	SCN080LDV	SCU080JLF	SCU080WXV	
HCN080HYV	HCU080KYV	SCN080LYV	SCU080JLV	SCU080WYV		
100 POUND	HCL100HNV	HCN100KEF	SCN100KNV	SCN100LXV	SCN100WEV	UCN100HNF
	HCL100KDF	HCN100KEV	SCN100LCF	SCN100LYF	SCN100WXF	UCN100HNV
	HCL100KDV	HCN100KXF	SCN100LCV	SCN100LYV	SCN100WXV	UCU100HNF
	HCN100HNV	HCN100KXV	SCN100LDF	SCN100WCF	SCN100WYF	UCU100HNV
	HCN100KCF	HCN100KYF	SCN100LDV	SCN100WCV	SCN100WYV	
	HCN100KCV	HCN100KYV	SCN100LEF	SCN100WDF	SCU100KNV	
	HCN100KDF	HCU100HNV	SCN100LEV	SCN100WDV	UCL100HNF	
HCN100KDV	SCL100KNV	SCN100LXF	SCN100WEF	UCL100HNV		
125 POUND	SCL125KNV	UCL125KNV				
	SCN125KNV	UCU125HNV				
	SCN125LYV	UCU125KNV				
	SCN125WYV					
	SCU125KNV					

Introduction

Delivery Inspection

Upon delivery, visually inspect crate, protective cover, and unit for any visible shipping damage. If signs of possible damage are evident, have the carrier note the condition on the shipping papers before the shipping receipt is signed, or advise the carrier of the condition as soon as it is discovered.

Nameplate Location

The nameplate is located at the rear of the machine and inside door. Provide the machine's serial number and model number when ordering parts or seeking technical assistance. Refer to *Figure 1*.

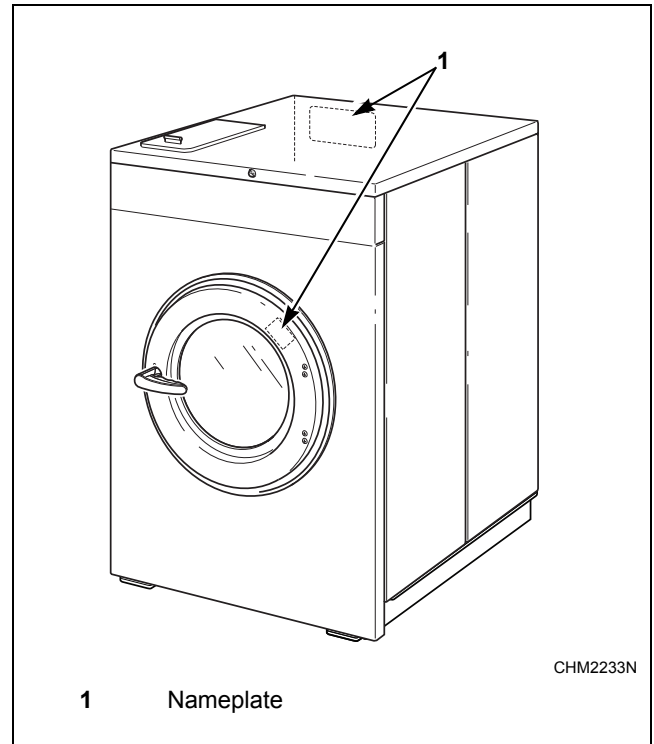

Figure 1

Replacement Parts

If literature or replacement parts are required, contact the source from which the machine was purchased or contact Alliance Laundry Systems at (920) 748-3950 for the name and address of the nearest authorized parts distributor.

Customer Service

Contact your local distributor or call:

Alliance Laundry Systems
Shepard Street
P.O. Box 990
Ripon, WI 54971-0990
U.S.A.
www.alliancelaundry.com

Phone: +1 (920) 748-3121
Ripon, Wisconsin

Alliance International
+32 56 41 20 54
Wevelgem, Belgium

Specifications and Dimensions

Specification	20	30	40	60	80	100	125	
Weight and Shipping Information								
Net weight, lbs. (kg)	335 (152)	460 (209)	550 (249)	695 (315)	1210 (549)	1260 (572)	2301 (1044)	
Standard shipping weight, lbs. (kg)	365 (166)	495 (225)	590 (268)	745 (338)	1260 (572)	1310 (594)	2384 (1081)	
Standard shipping volume, ft ³ (m ³)	26.5 (0.75)	35.8 (1.01)	43.9 (1.24)	57.3 (1.62)	81.3 (2.30)	87.3 (2.5)	163 (4.3)	
Standard shipping dimensions (WxHxD), in. (mm)	28x33.8x48.4 (711x859x 1229)	31.5x38.3x51.3 (800x973x 1303)	32.5x43.5x53.6 (826x1105x 1361)	37.5x46.9x56.3 (953x1191x 1430)	44x54.5x58.6 (1118x1384x 1488)	44x58.5x58.6 (1118x1486x 1488)	56x61.5x77.8 (1422x1562x 1976)	
Slat crate shipping weight, lbs. (kg)	450 (204)	590 (268)	690 (313)	860 (390)	1385 (628)	1435 (651)	2492 (1130)	
Slat crate shipping volume, ft ³ (m ³)	36.2 (1.04)	47.3 (1.34)	54.1 (1.53)	77.6 (2.20)	105 (2.97)	112.4 (3.18)	173 (4.8)	
Slat crate shipping dimensions (WxHxD), in. (mm)	32.5x36.8x49.8 (826x935x 1240)	36x41.3x55 (914x1049x 1397)	37x45.9x55 (940x1166x 1397)	42x49.9x64 (1067x1267x 1626)	48.5x57.5x65.1 (1232x1461x 1654)	48.5x61.5x65.1 (1232x1562x 1654)	59x64.5x80 (1499x1638x 2032)	
Wash Cylinder Information								
Cylinder diameter, in. (mm)	21 (533)	24 (610)	26.25 (667)	30 (762)	36 (914)	36 (914)	43 (1092)	
Cylinder depth, in. (mm)	13.75 (349)	16 (406)	20.25 (514)	22 (559)	22 (559)	26 (660)	24 (610)	
Cylinder volume, ft ³ (l)	2.76 (78.1)	4.19 (118)	6.34 (180)	9.00 (255)	12.95 (367)	15.32 (434)	19.2 (544)	
Perforation size, in. (mm)	0.188 (4.78)	0.188 (4.78)	0.188 (4.78)	0.188 (4.78)	0.188 (4.78)	0.188 (4.78)	0.188 (4.78)	
Perforation open area, %	17.3	18.6	18.8	18.8	19.6	20.2	24	
Door Opening Information								
Door opening size, in. (mm)	11.63 (295)	14.34 (364)	16.25 (413)	16.25 (413)	18.5 (470)	18.5 (470)	20 (508)	
Height of door bottom above floor, in. (mm)	14.38 (365)	14 (356)	14.56 (370)	14.94 (379)	17.91 (455)	17.91 (455)	29 (737)	
Height of door opening above floor, in. (mm)	17 (432)	17 (431)	17.74 (451)	18.12 (460)	20.77 (528)	20.77 (528)	30.25 (768)	
Power Consumption								
Average power used per cycle, kW-hr. (x-voltage shown)	No load	.05	.09	.10	.15	.19	.19	.63
	80 % load	.06	.11	.14	.22	.28	.28	.64
Estimated Building Heat Load								
HVAC load, Btu/hr. (Kcal/hr.) (Non-heat models)	400 (101)	450 (113)	510 (129)	750 (189)	950 (239)	950 (239)	1200 (302)	
Drive Train Information								
Number of motors in drive train	1	1	1	1	1	1	1	
Drive motor power, hp (kW)	*	2 (1.5)	2 (1.5)	3 (2.2)	5 (3.7)	5 (3.7)	7.5 (5.6)	

(continued)

(continued)

Specification		20	30	40	60	80	100	125	
Cylinder Speeds									
Gentle wash/reverse speed, RPM (G)		37 (0.4)	34 (0.4)	33 (0.4)	31 (0.4)	28 (0.4)	28 (0.4)	26 (0.4)	
Wash/reverse speed, RPM (G)		51 (0.8)	48 (0.8)	46 (0.8)	43 (0.8)	39 (0.8)	39 (0.8)	36 (0.8)	
Distribution speed, RPM (G)		92 (2.5)	86 (2.5)	82 (2.5)	77 (2.5)	70 (2.5)	70 (2.5)	64 (2.6)	
Extract Speed 1 (very low), RPM (G)		301 (27)	282 (27)	269 (27)	252 (27)	230 (27)	230 (27)	256 (40)	
Extract Speed 2 (low), RPM (G)		518 (80)	485 (80)	464 (80)	434 (80)	396 (80)	396 (80)	362 (80)	
Extract Speed 3 (medium), RPM (G)		579 (100)	542 (100)	518 (100)	485 (100)	443 (100)	443 (100)	405 (100)	
Extract Speed 4 (high), RPM (G)		648 (120)	606 (120)	579 (120)	542 (120)	495 (120)	495 (125)	444 (120)	
Extract Speed 5 (very high), RPM (G)		710 (150)	664 (150)	635 (150)	594 (150)	542 (150)	542 (150)	479 (140)	
Extract Speed 6 (ultra high), RPM (G)		819 (200)	766 (200)	733 (200)	686 (200)	626 (200)	568 (165)	N/A	
Direct Steam Heating (Optional)									
Steam inlet connection size, NPT		1/2	1/2	1/2	1/2	1/2	1/2	3/4	
Number of steam inlets		**	**	1	1	1	1	1	
Steam required to raise bath water temperature 10°F (10°C), lbs. (kg)	LOW	.74 (0.34)	.94 (0.43)	2.09 (0.94)	3.80 (1.63)	3.80 (1.72)	3.80 (1.72)	3.64 (1.65)	
	MED	1.07 (0.49)	1.28 (0.58)	2.40 (1.09)	4.65 (2.11)	4.65 (2.11)	5.49 (2.49)	5.17 (2.35)	
	HIGH	1.44 (0.65)	1.74 (0.79)	2.84 (1.29)	5.79 (2.63)	5.79 (2.63)	6.84 (3.10)	7.78 (3.52)	
Average steam use per cycle, bhp		.34	.41	.78	.98	1.34	1.58	1.14	
Electrical Heating									
Total electrical heating capacity, kW	Input Voltage								
	200V	5.4	5.4	10.8	10.8	19.1	N/A	N/A	
	240V	7.8	7.8	15.6	15.6	27.4	N/A	N/A	
	380V	6.5	6.5	13.0	13.0	17.2	34.4	34.4	
	415V	7.8	7.8	15.5	15.5	20.5	41.0	41	
	480V	N/A	N/A	15.6	15.6	27.4	54.8	54.8	
Electrical heating elements		3	3	6	6	6	12	12	
Electrical heat element size, kW		2.6	2.6	2.6	2.6	4.2	2.6	4.2	
Noise Emissions									
dBA	Wash	58	58	58	58	58	58	N/A	
	Extract	100G	52	59	59	59	69	69	N/A
		200G	61	66	66	66	76	76	N/A

* For B, Q, and X-voltage models = 1 hp (.75 kW) and for N and P-voltage models = 2 hp (1.7 kW)

** 20 and 30 pound models can be prep for steam and a kit is available for conversion.

N/A = Not Applicable

Specifications and Dimensions

NOTE: Refer to following page for dimensions.

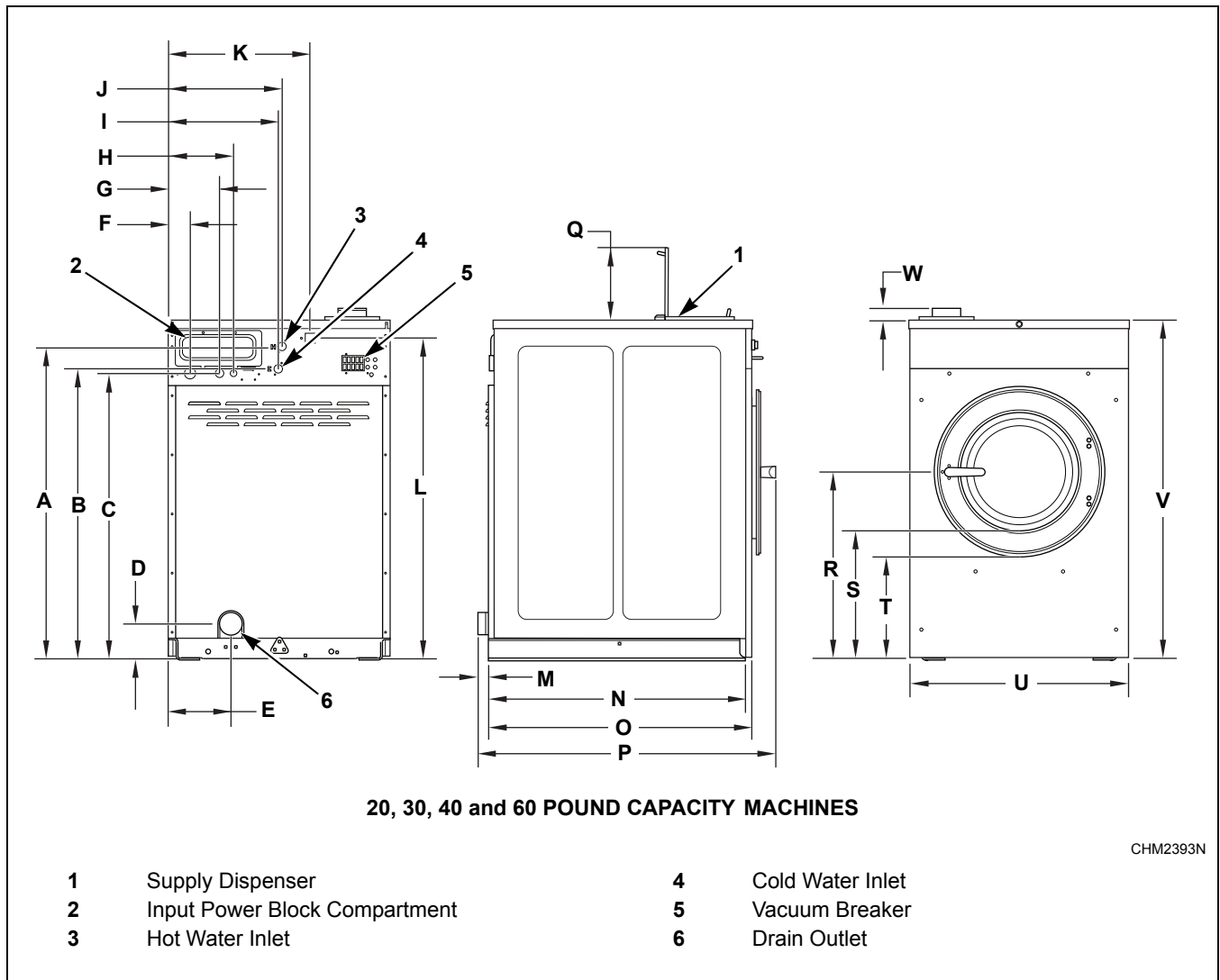

Figure 2

Machine Capacity Dimensions				
Dimensions	20	30	40	60
A	38.0 in. (965 mm)	40.9 in. (1039 mm)	43.2 in. (1097 mm)	45.9 in. (1166 mm)
B	35.0 in. (889 mm)	37.9 in. (963 mm)	40.2 in. (1021 mm)	42.8 in. (1087 mm)
C	34.5 in. (876 mm)	37.5 in. (953 mm)	39.7 in. (1008 mm)	42.4 in. (1077 mm)
D	4.7 in. (119 mm)	4.1 in. (104 mm)	4.5 in. (114 mm)	4.9 in. (124 mm)
E	7.8 in. (198 mm)	9.3 in. (236 mm)	8.8 in. (224 mm)	9.9 in. (251 mm)
F	3 in. (76 mm)	3 in. (76 mm)	3 in. (76 mm)	3 in. (76 mm)
G	6.9 in. (175 mm)	6.9 in. (175 mm)	6.9 in. (175 mm)	6.9 in. (175 mm)
H	8.8 in. (224 mm)	8.8 in. (224 mm)	8.8 in. (224 mm)	8.8 in. (224 mm)
I	15.2 in. (386 mm)	15.2 in. (386 mm)	15.2 in. (386 mm)	19.9 in. (505 mm)
J	15.7 in. (399 mm)	15.7 in. (399 mm)	15.7 in. (399 mm)	20.4 in. (518 mm)
K	N/A	N/A	19.5 in. (495 mm)	22.9 in. (582 mm)
L	38 in. (965 mm)	40.9 in. (1040 mm)	44.6 in. (1133 mm)	47.3 in. (1201 mm)
M	0.3 in. (9 mm)	0.3 in. (9 mm)	2.0 in. (51 mm)	2.0 in. (51 mm)
N	26.8 in. (681 mm)	31.5 in. (800 mm)	35.5 in. (902 mm)	38.6 in. (980 mm)
O	27.3 in. (693 mm)	31.8 in. (808 mm)	37 in. (940 mm)	39.5 in. (1003 mm)
P	30.9 in. (785 mm)	35.3 in. (897 mm)	42.3 in. (1074 mm)	44.7 in. (1135 mm)
R	23.0 in. (584 mm)	24.0 in. (610 mm)	26.0 in. (660 mm)	26.4 in. (671 mm)
Q	9.0 in. (254 mm)	9.0 in. (254 mm)	9.0 in. (254 mm)	9.0 in. (254 mm)
S	17.0 in. (229 mm)	17.0 in. (432 mm)	17.7 in. (450 mm)	18.1 in. (460 mm)
T	14.4 in. (366 mm)	14 in. (356 mm)	14.6 in. (371 mm)	14.9 in. (379 mm)
U	26.0 in. (660 mm)	29.0 in. (737 mm)	30.6 in. (777 mm)	34.1 in. (866 mm)
V	42.0 in. (1067 mm)	45.0 in. (1143 mm)	47.2 in. (1199 mm)	50.0 in. (1270 mm)
W	1.5 in. (38 mm)	1.5 in. (38 mm)	1.5 in. (38 mm)	1.5 in. (38 mm)

Specifications and Dimensions

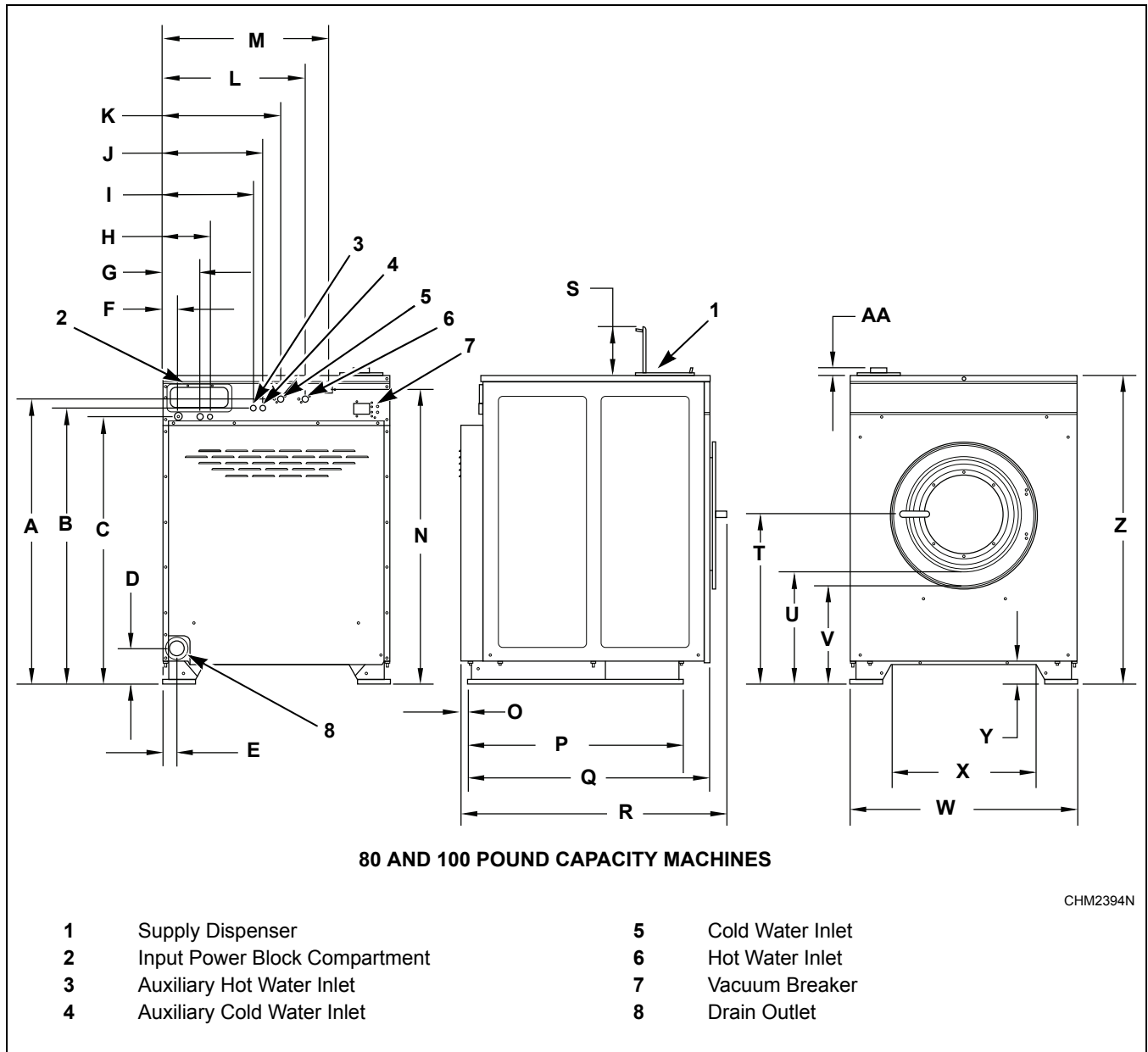

Figure 3

Machine Capacity Dimensions for 80 and 100 Pound Models				
A	51.8 in. (1316 mm)	O	1.4 in. (35 mm)	
B	50.3 in. (1278 mm)	P	39.2 in. (996 mm)	
C	48.7 in. (1237 mm)	Q	80	44.2 in. (1122 mm)
			100	48.2 in. (1223 mm)
D	6.4 in. (163 mm)	R	80	48.6 in. (1234 mm)
			100	52.6 in. (1336 mm)
E	2.6 in. (66 mm)	S	9.0 in. (229 mm)	
F	3.0 in. (76 mm)	T	30.9 in. (785 mm)	
G	6.9 in. (175 mm)	U	20.8 in. (528 mm)	
H	8.8 in. (224 mm)	V	17.9 in. (455 mm)	
I	16.7 in. (424 mm)	W	41.5 in. (1054 mm)	
J	18.2 in. (462 mm)	X	26.2 in. (665 mm)	
K	21.7 in. (551 mm)	Y	3.6 in. (91 mm)	
L	26.2 in. (665 mm)	Z	56.2 in. (1427 mm)	
M	30.4 in. (772 mm)	AA	1.5 in. (38 mm)	
N	53.6 in. (1361 mm)			

Specifications and Dimensions

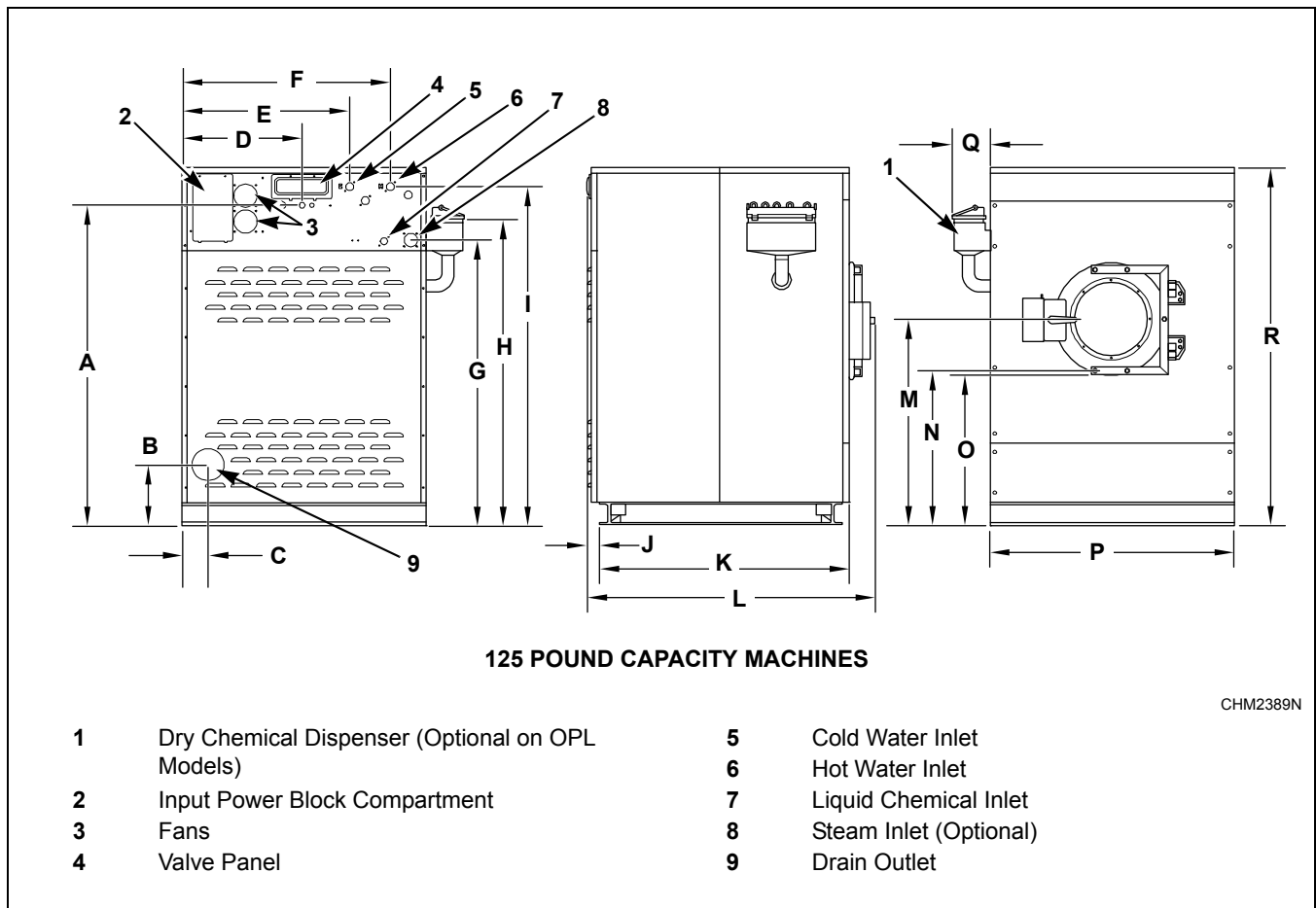

Figure 4

Machine Capacity Dimensions for 125 Pound Models			
A	63.04 in. (1601 mm)	J	2.29 in. (58 mm)
B	11.69 in. (297 mm)	K	49.02 in. (1245 mm)
C	5.01 in. (127 mm)	L	56.06 in. (1424 mm)
D	23.65 in. (601 mm)	M	40.16 in. (1020 mm)
E	33.03 in. (839 mm)	N	30.16 in. (766 mm)
F	39.28 in. (998 mm)	O	28.28 in. (718 mm)
G	55.81 in. (1418 mm)	P	48 in. (1219 mm)
H	60.21 in. (1529 mm)	Q	7.94 in. (202 mm)
I	65.77 in. (1671 mm)	R	70.47 in. (1790 mm)

Mounting Bolt Hole Locations – 20, 30, 40 and 60 Pound Models

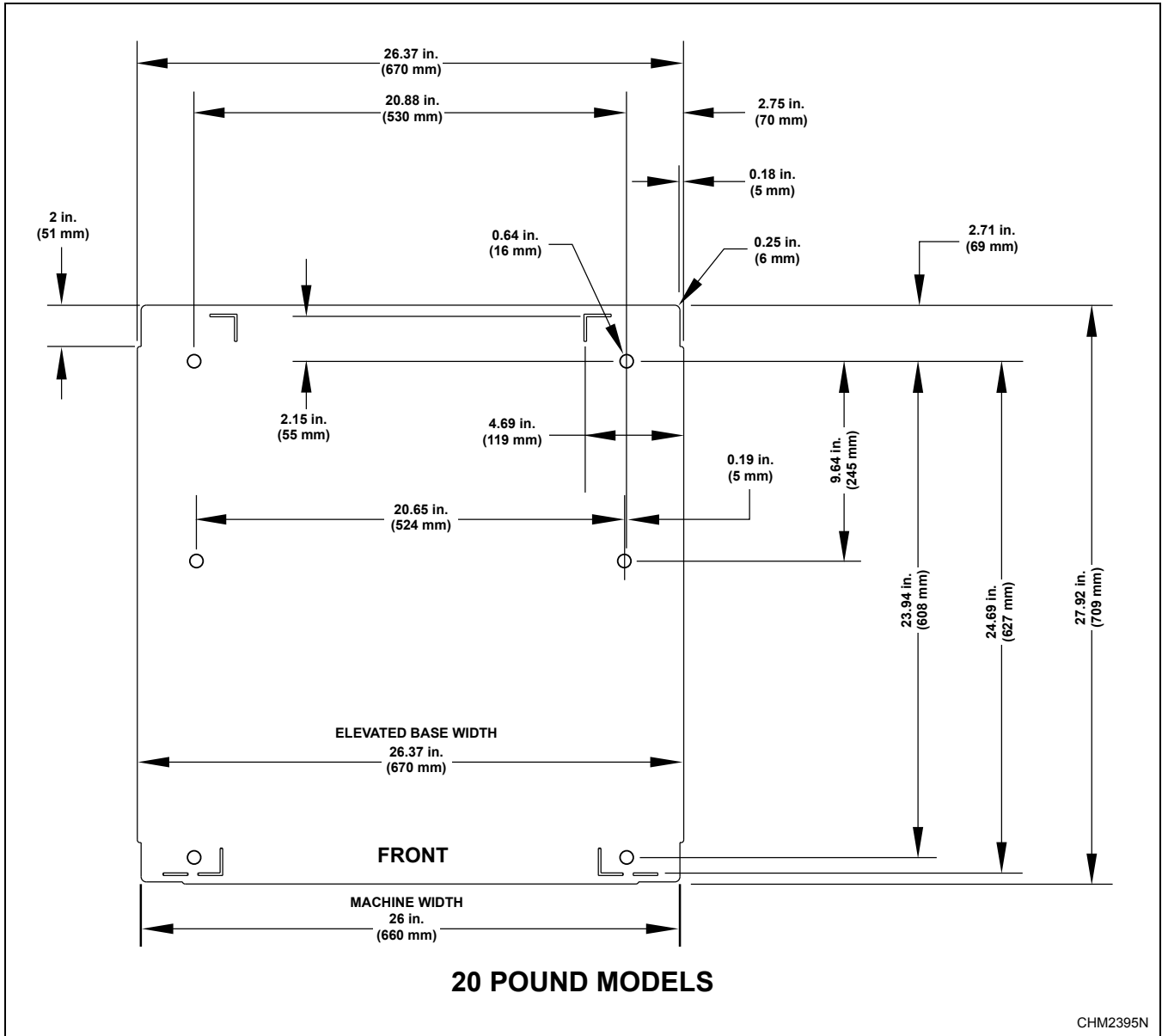

Figure 5

Specifications and Dimensions

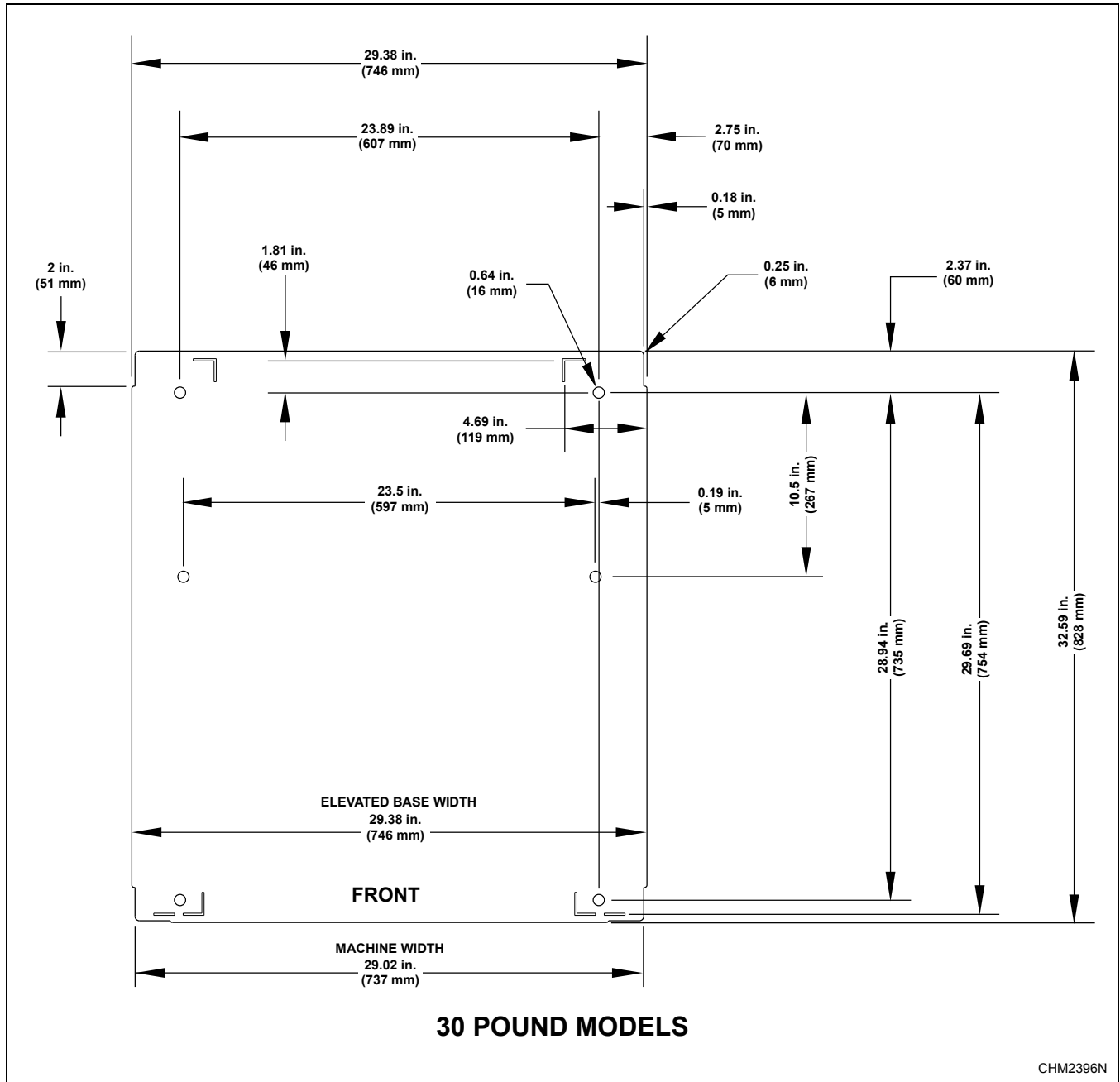

Figure 6

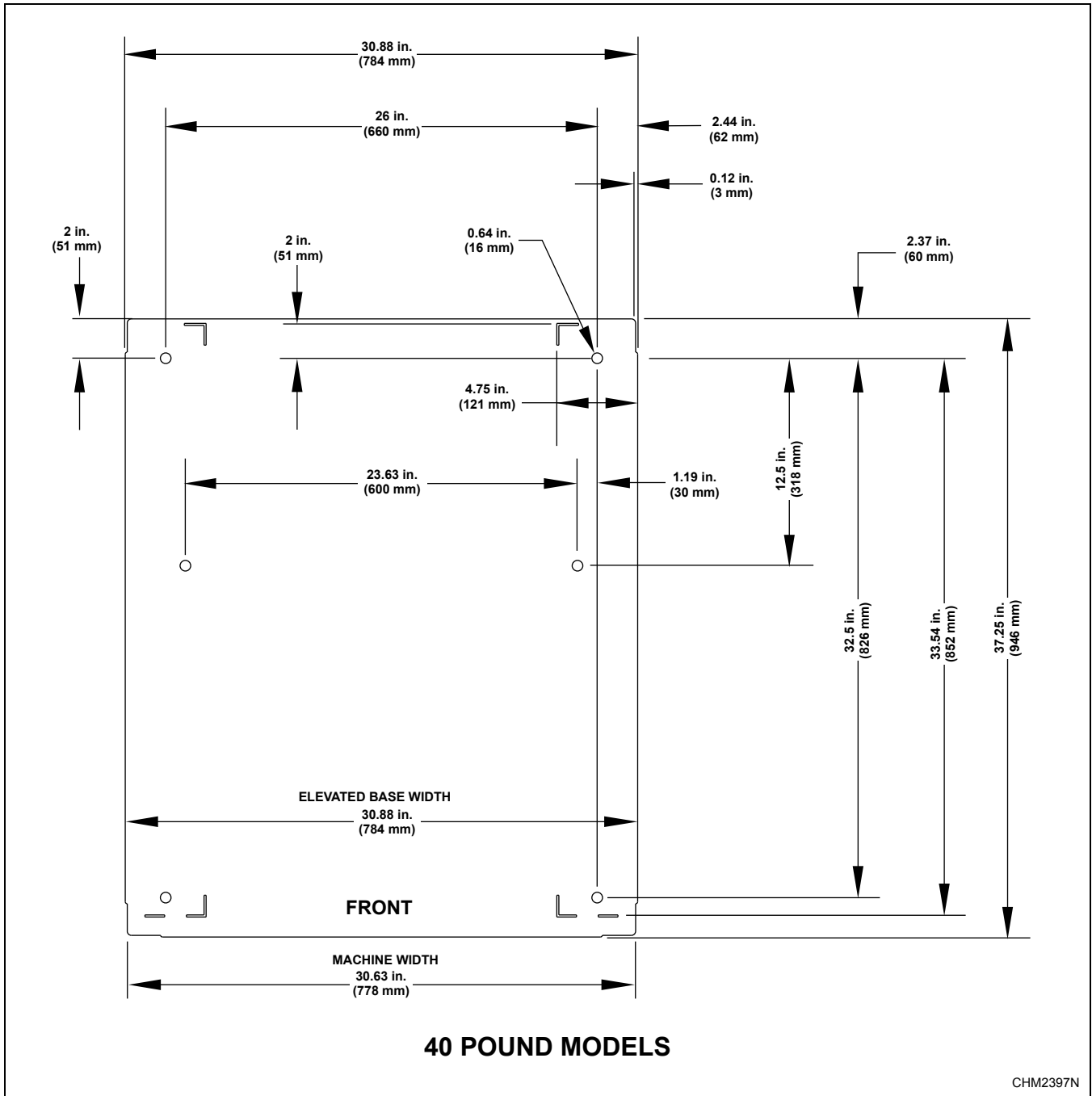

Figure 7

Specifications and Dimensions

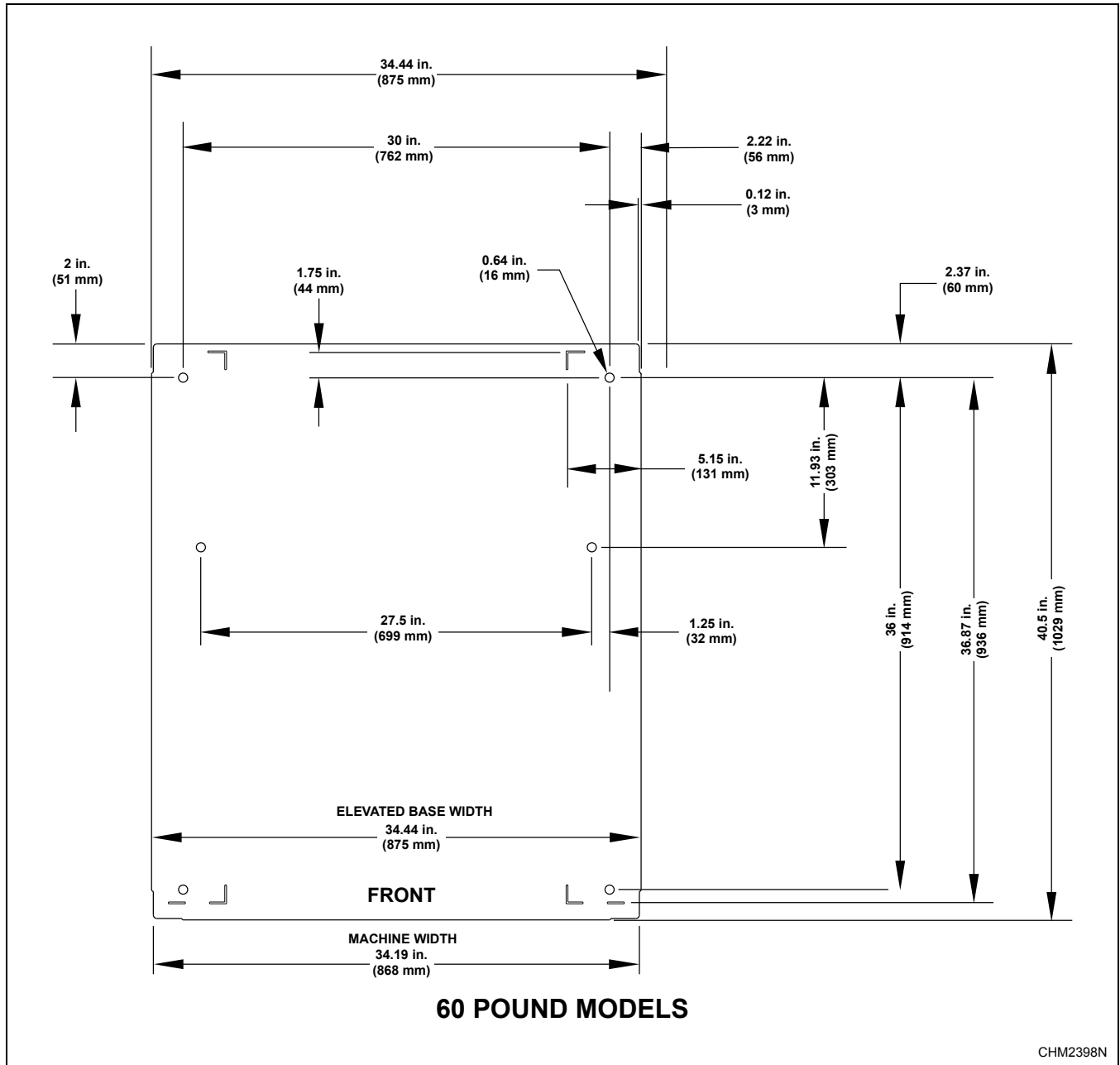

Figure 8

Mounting Bolt Hole Location – 80 and 100 Pound Models

Refer to *Table 1*.

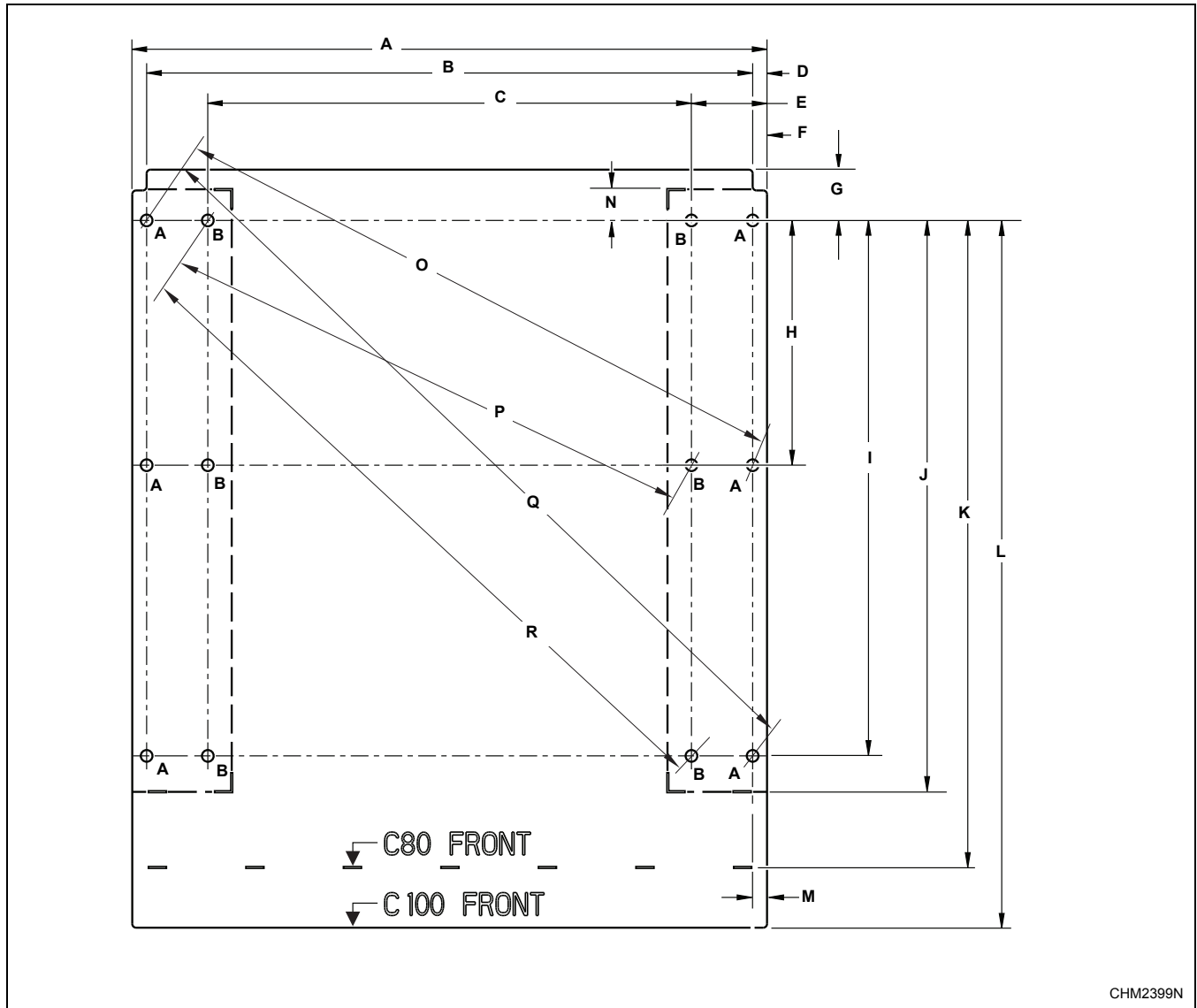

Figure 9

NOTE: For single machine installations or two machines installed back to back, use the outside bolt holes marked “A”. For multiple machines installed side by side with minimum clearance, use the inside bolt holes marked “B”.

Specifications and Dimensions

		80	100
A		41.5 in. (1054 mm)	41.5 in. (1054 mm)
B		39.62 in. (1006 mm)	39.62 in. (1006 mm)
C		31.62 in. (803 mm)	31.62 in. (803 mm)
D		.94 in. (24 mm)	.94 in. (24 mm)
E		4.94 in. (124 mm)	4.94 in. (124 mm)
F		6.63 in. (164 mm)	6.63 in. (164 mm)
G		3.3 in. (84 mm)	3.3 in. (84 mm)
H		16 in. (406 mm)	16 in. (406 mm)
I		35 in. (889 mm)	35 in. (889 mm)
J		37.3 in. (947 mm)	37.3 in. (947 mm)
K		42.2 in. (1073 mm)	N/A
L		N/A	46.2 in. (1260 mm)
M		1 in. (25 mm)	1 in. (25 mm)
N		1.96 in. (50 mm)	1.96 in. (50 mm)
O	Outside	42.72 in. (1085 mm)	35.43 in. (900 mm)
P	Inside	52.86 in. (1342 mm)	47.16 in. (1197 mm)
Q	Outside	35.43 in. (900 mm)	42.72 in. (1085 mm)
R	Inside	47.16 in. (1197 mm)	52.86 in. (1342 mm)

Table 1

Mounting Bolt Hole Locations – 125 Pound Models

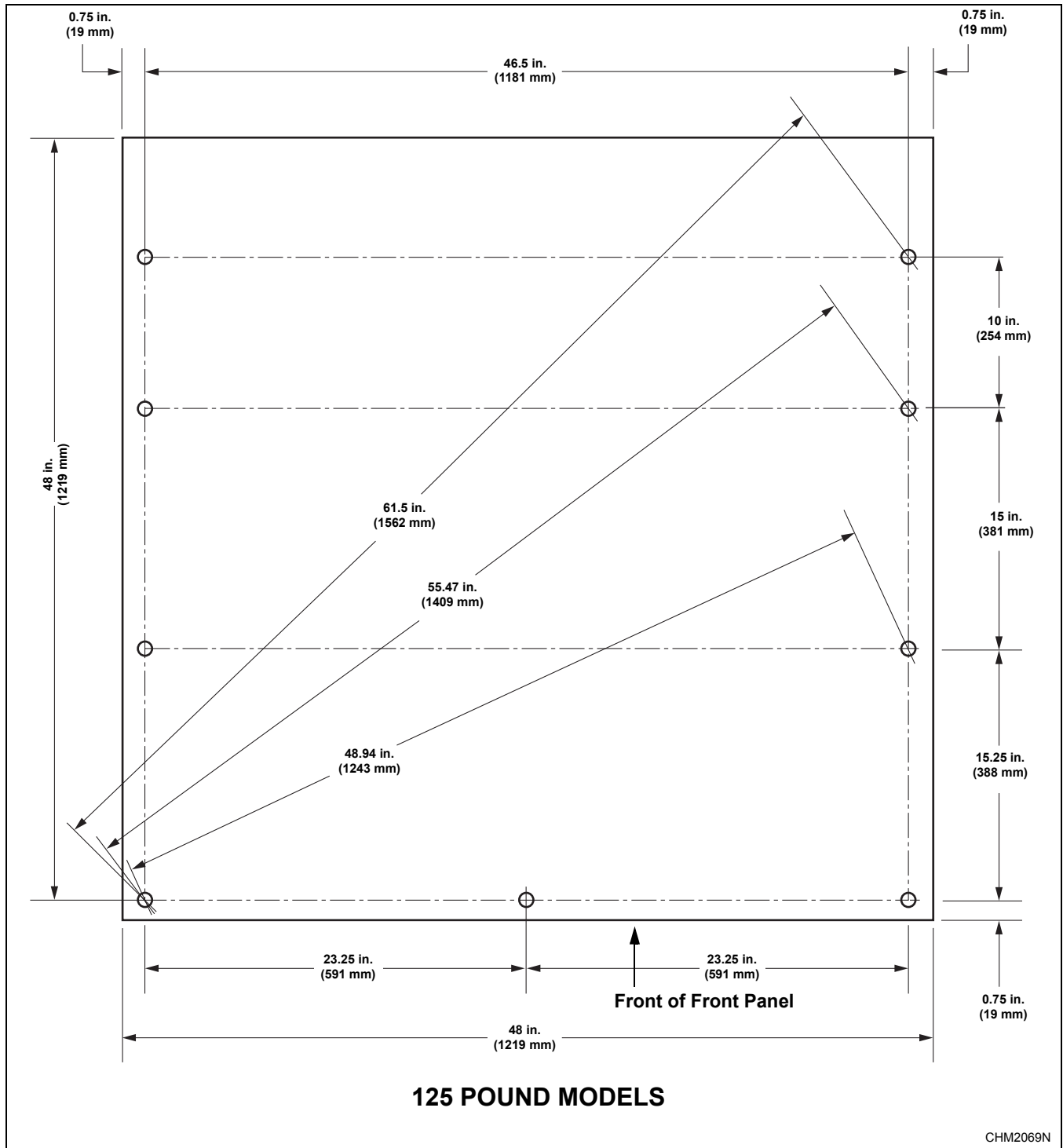

Figure 10

Floor Mounting Layout – 20, 30, 40 and 60 Pound Models

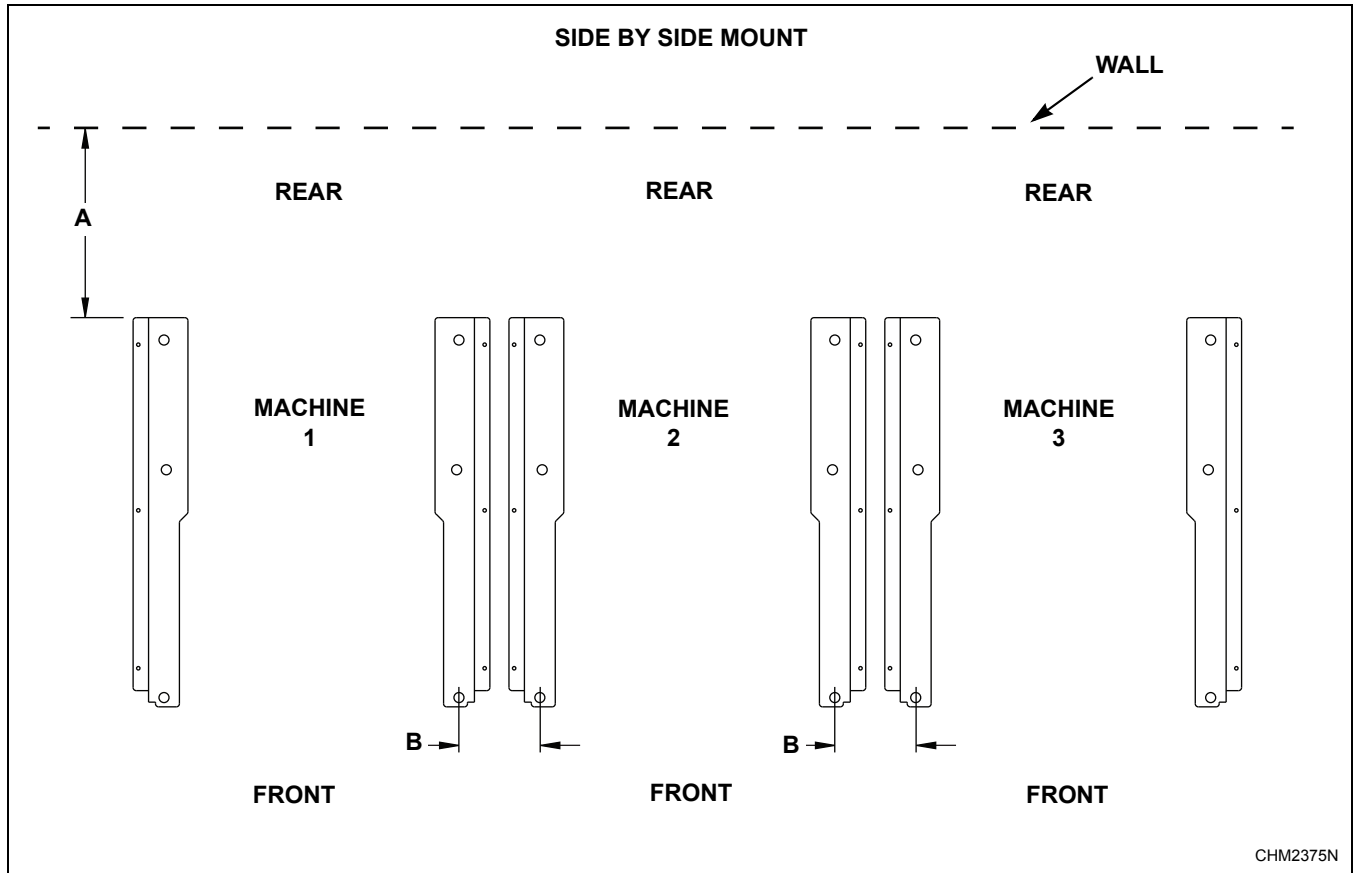
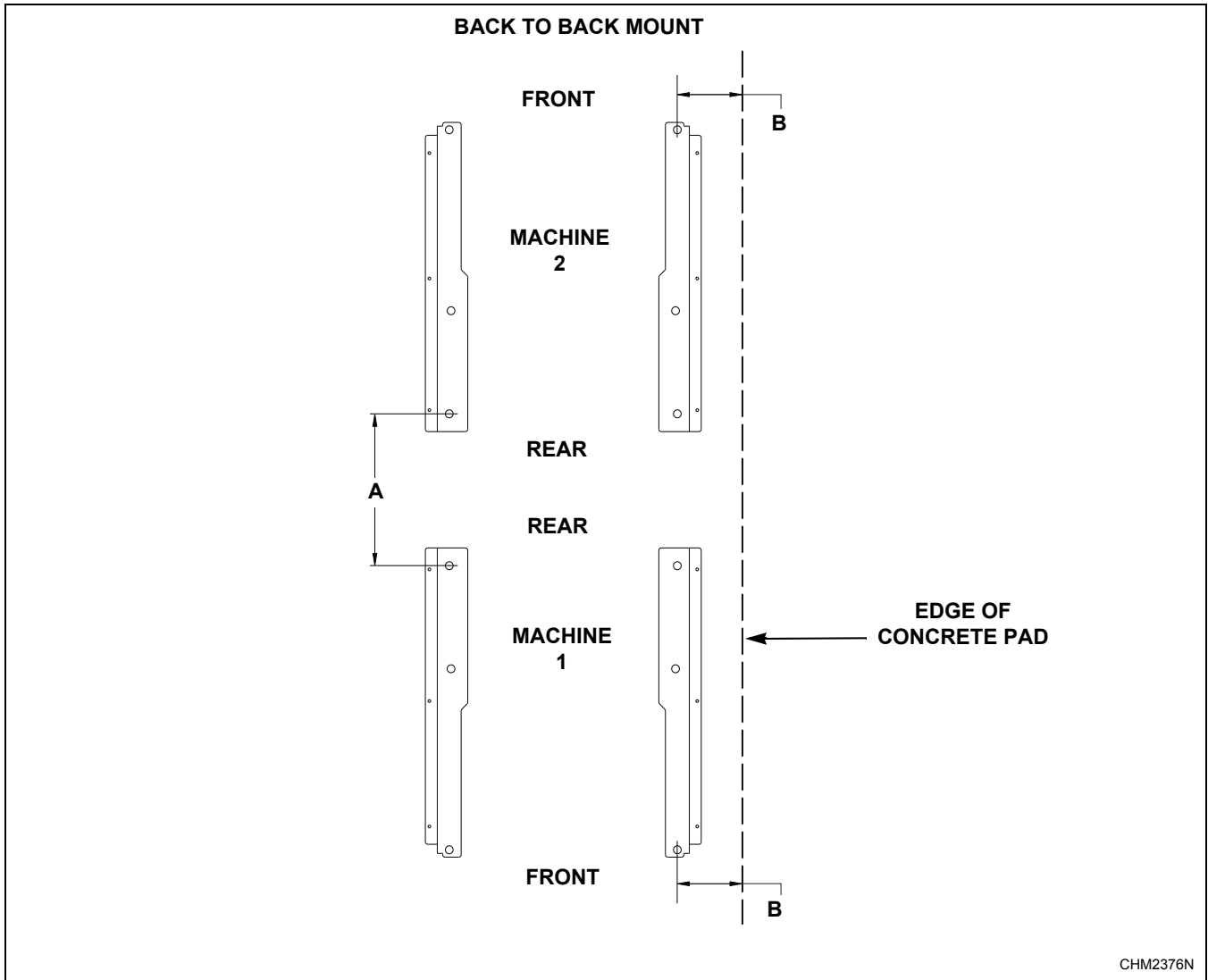

Figure 11

Floor Layout Specifications					
Specifications	20	30	40	60	
A (Minimum distance to wall)	20 in. (508 mm)	20 in. (508 mm)	20 in. (508 mm)	20 in. (508 mm)	
B	Mounted Without Bases (minimum)	5.14 in. (131 mm)	5.12 in. (130 mm)	4.63 in. (118 mm)	4.06 in. (103 mm)
	Mounted With Bases	5.5 in. (139 mm)	5.5 in. (139 mm)	4.88 in. (124 mm)	4.44 in. (112 mm)



CHM2376N

Figure 12

Floor Layout Specifications				
Specifications	20	30	40	60
A (min.)	28.3 in. (719 mm)	27.6 in. (702 mm)	28.0 in. (710 mm)	27.5 in. (699 mm)
B (min.)	5.2 in. (152 mm)	5.2 in. (152 mm)	5.2 in. (152 mm)	7.4 in. (152 mm)

Floor Layout – 80 and 100 Pound Models

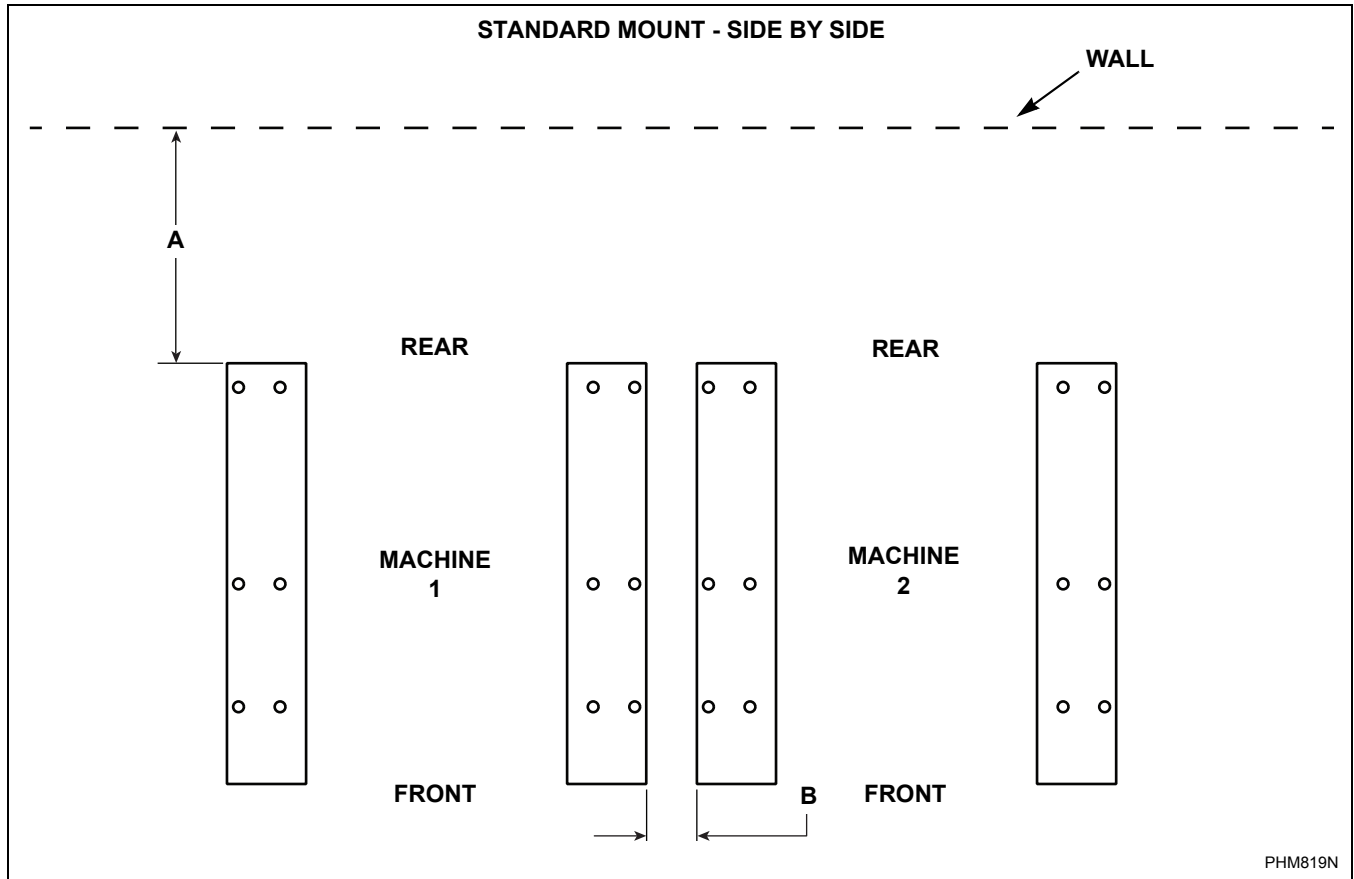

Figure 13

Floor Layout Specifications	
Specifications	80-100
A (Distance to wall)	24 in. minimum (610 mm)
B*	6 in. minimum (152 mm)

* Minimum adjacent unit bolt spacing

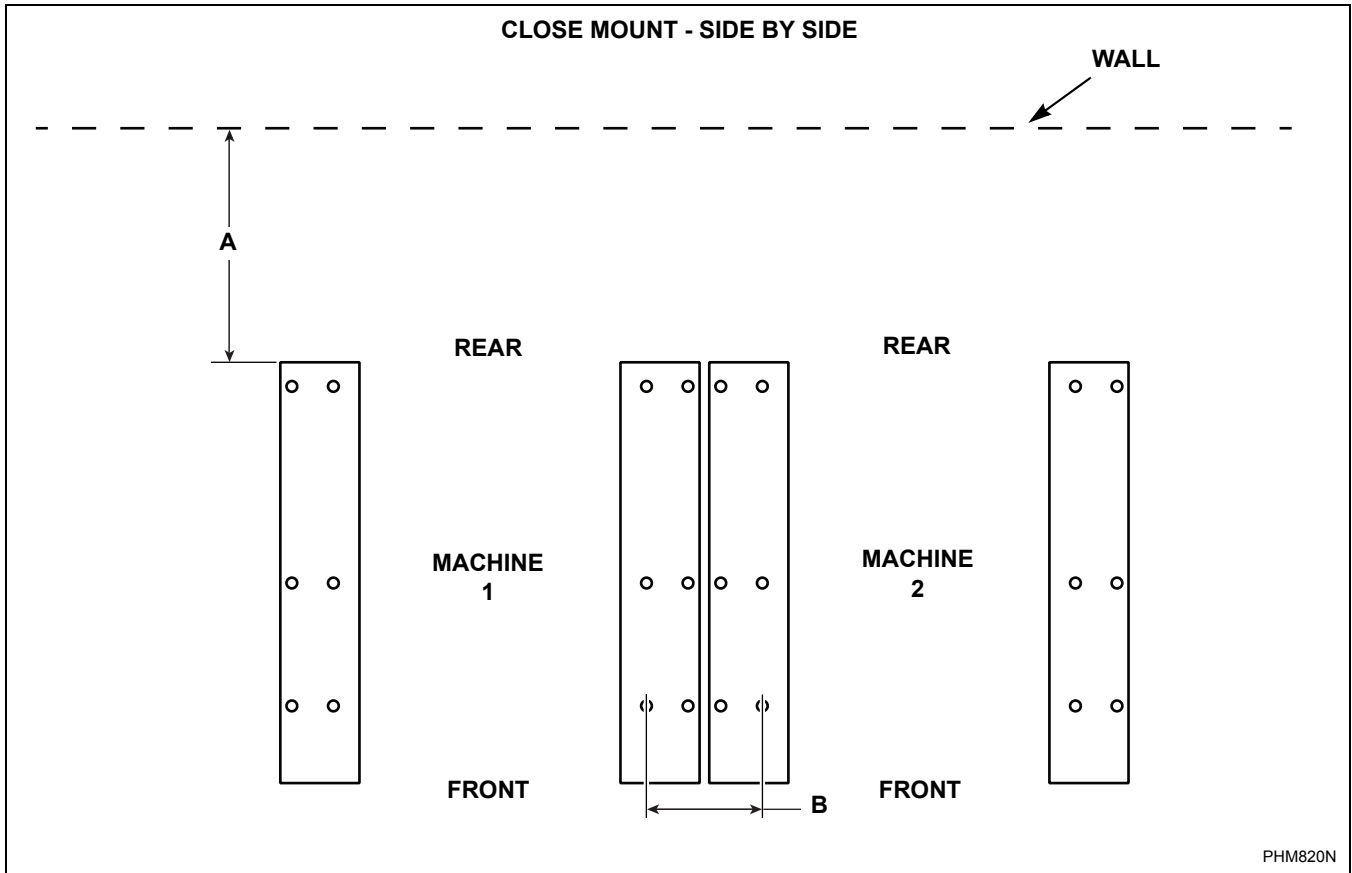

Figure 14

Floor Layout Specifications	
Specifications	80-100
A (Distance to wall)	24 in. (610 mm)
B*	9.88 in. minimum (251 mm)

* Minimum adjacent unit bolt spacing

IMPORTANT: When close mounting, bolt machine using inside bolt holes.

Specifications and Dimensions

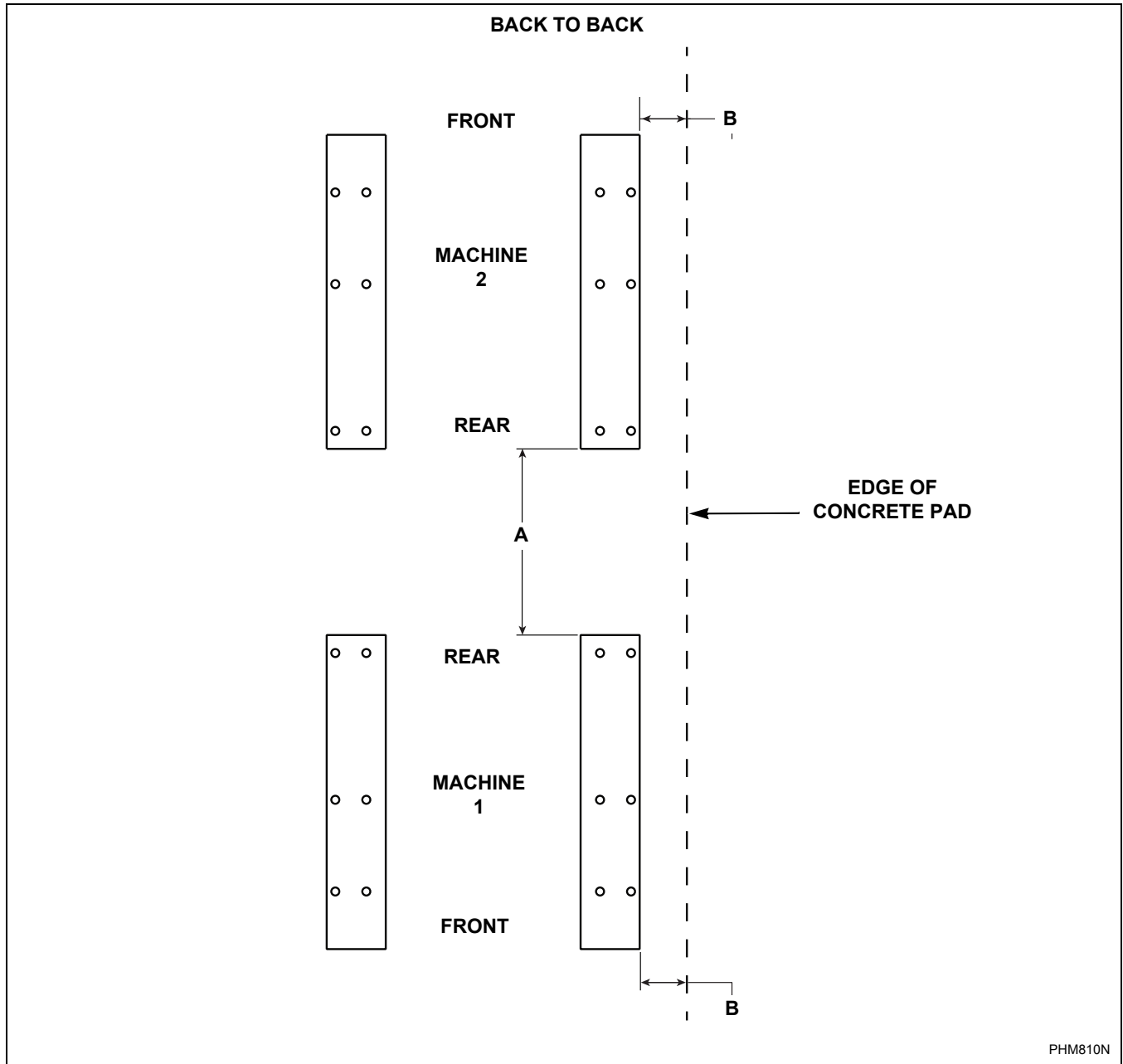

Figure 15

Floor Layout Specifications	
Specifications	80-100
A	33.3 in. minimum (846 mm)
B	6.9 in. minimum (175 mm)

Installation

Pallet Jack Cover Plate Removal (80 and 100 Pound Models Only)

Prior to installing an 80 and 100 pound machine, the optional pallet jack cover plate can be removed in preparation of re-installing to machine base frame after machine installation.

1. Locate cover plate on back panel.
2. Remove back panel.
3. Remove all hardware holding cover plate on back panel, refer to *Figure 16*. DO NOT DISCARD HARDWARE.
4. Remove cover plate.

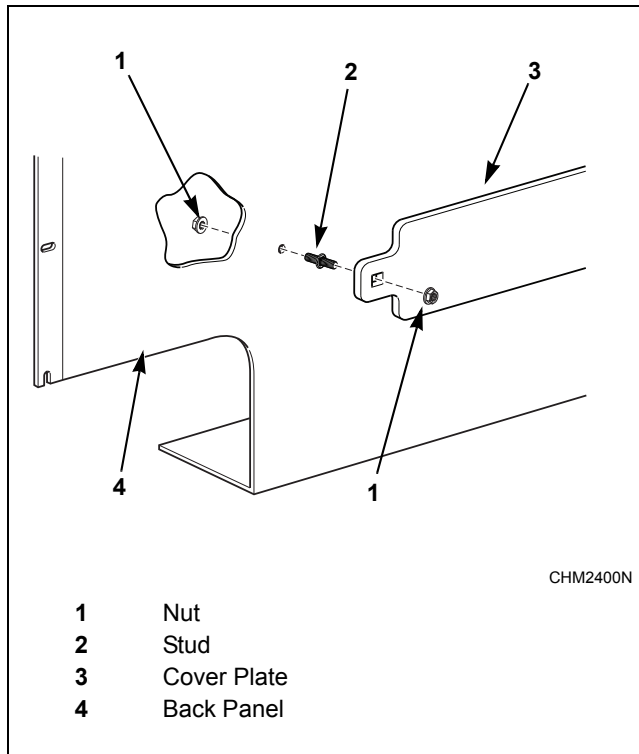

Figure 16

5. Re-install back panel.

NOTE: Refer to Pallet Jack Plate Installation to install cover plate to machine base after machine installation.

Single Machine Foundation Requirements

A minimum 3500 psi (refer to rating per supplier) reinforced concrete set on a prepared bed is required for all new machine installations.

NOTE: Do not mount on wooden floors, tile floors, elevated floor levels, or over basements or crawl spaces because of the high extract speed and the G-forces exerted. For 80 pound models and larger, do not mount on metal base frames.

Thoroughness of detail must be stressed with all foundation work to ensure a stable unit installation, eliminating possibilities of excessive vibration during extract.

	WARNING
To reduce the risk of fire, serious injury, property damage and/or death, install the machine on a level (within 3/8 inch), uncovered concrete floor of sufficient strength at grade.	
<small>W787</small>	

For new foundations a mounting bolt template or elevated metal base frames are available at extra cost. For all installations a concrete hardware kit is available at extra cost.

The machine must be anchored to a smooth level surface so that the entire base of the machine is supported and rests on the mounting surface.

IMPORTANT: Do not permanently support the machine on only four points with spacers. Grouting is required and spacers must be removed.

Machine Installation with Existing Floor

The existing floor slab must meet minimum requirements shown in *Table 2* per machine model. The floor must be reinforced concrete without voids under slab. If the floor meets these requirements and an elevated pad is NOT desired, refer to *Figures 18, 21, 30, and 33* and proceed to **Machine Mounting and Grouting** section.

Installation

Elevated Pad Installation with Existing Floor

The existing floor slab must meet minimum requirements shown in *Table 2* per machine. The floor must be reinforced concrete without voids under slab. If the slab meets these requirements and an elevated pad is desired, refer to *Figures 19, 22, 31, and 34* and proceed to ***Machine Foundation and Pad Installation*** section.

Elevated Base Frame Installation with Existing Floor

The existing floor slab must meet minimum requirements shown in *Table 2* per machine. The floor must be reinforced concrete without voids under slab. If the slab meets these requirements and an elevated base frame is desired, refer to *Figures 17, 18, 20, 21, 23, 24 and 26* and proceed to ***Machine Mounting and Grouting*** section.

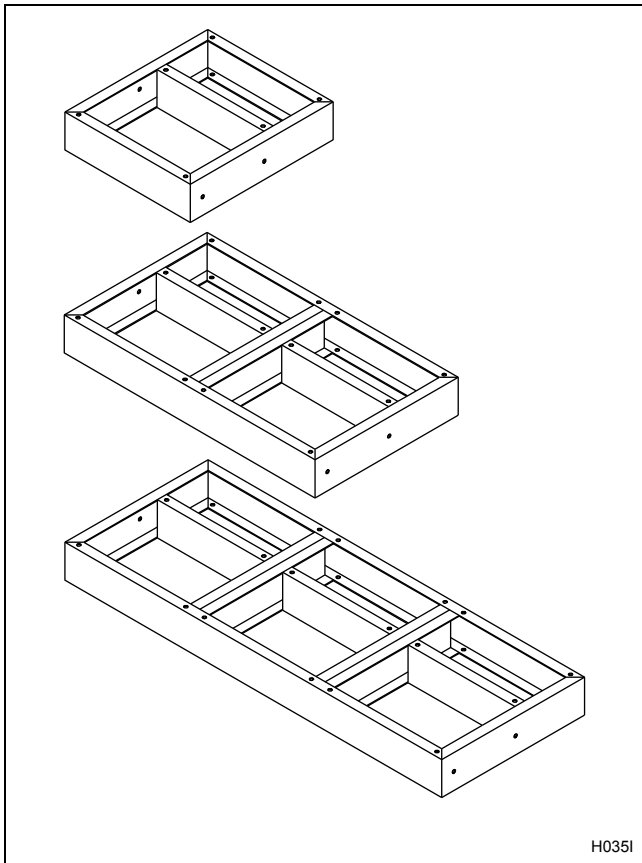

Figure 17

New Foundation

If the existing floor slab does not meet the single machine foundation requirements per model, refer to *Figures 20, 23, 32, and 35* and proceed to ***Machine Foundation and Pad Installation*** section.

Isolated Pad Installation

This type of installation is NOT recommended. Installer MUST consult a Structural Engineer for concrete specifications and requirements for installations that will not be tied into adjacent foundations.

IMPORTANT: The above instructions and recommendations are conservative specifications for a typical installation based on consultations with a structural engineer. Alliance Laundry Systems stands behind all installations meeting these specifications. For alternate installation specifications based on your soil type, location, building structure, unique floor geometry, machine types, and utilities, consult a structural engineer in your local area.

Machine Foundation and Pad Installation

A concrete pad may be constructed to elevate a machine. Care must be exercised in the design of the pad due to the force exerted by the machine during extract. This concrete pad, recommended not to exceed 8 inches (203 mm) above existing floor, must be placed, reinforced with rebar and tied to the existing floor. Refer to *Table 2* and *Figure 18* through *Figure 35* for multiple machine installations.

Model		20	30	40	60	80-100	125
Minimum Foundation Thickness	F-speed	4 in. (102 mm)	4 in. (102 mm)	4 in. (102 mm)	4 in. (102 mm)	6 in. (152 mm)	N/A
	V-speed			6 in. (152 mm)	6 in. (152 mm)	9 in. (229 mm)	12 in. (305 mm)
Minimum Excavation Depth	F-speed	8 in. (203 mm)	8 in. (203 mm)	8 in. (203 mm)	8 in. (203 mm)	12 in. (305 mm)	N/A
	V-speed			12 in. (305 mm)	12 in. (305 mm)	15 in. (381 mm)	18 in. (457 mm)
Minimum Pad Size							
Single machine (w x d)		31.4 in. x 34.8 in. (798 mm x 884 mm)	34.4 in. x 39.5 in. (874 mm x 1003 mm)	36.5 in. x 43.5 in. (927 mm x 1105 mm)	44.8 in. x 50.6 in. (1139 mm x 1285 mm)	57.5 in. x 49.2 in. (1461 mm x 1250 mm)	72 in. x 72 in. (1828 mm x 1828 mm)
Two machines, Side-by-side		57.4 in. x 34.8 in. (1458 mm x 884 mm)	67.4 in. x 39.5 in. (1712 mm x 1003 mm)	67.1 in. x 43.5 in. (1704 mm x 1105 mm)	78.9 in. x 50.6 in. (2004 mm x 1285 mm)	93.0 in. x 49.2 in. (2362 mm x 1250 mm)	133 in. x 72 in. (3378 mm x 1828 mm)
Two machines, Back-to-back		31.4 in. x 85.7 in. (798 mm x 2177 mm)	34.4 in. x 95 in. (874 mm x 2413 mm)	36.5 in. x 103.1 in. (927 mm x 2619 mm)	44.8 in. x 113.2 in. (1138 mm x 2875 mm)	51.5 in. x 119.9 in. (1308 mm x 3046 mm)	72 in. x 156 in. (1828 mm x 3962 mm)

NOTE: Inside and outside mounting only available on 80 and 100 pound models.

N/A = Not Applicable

Table 2

IMPORTANT: Do NOT install a pad on top of the existing floor. The foundation and pad must be constructed and tied together as one piece.

If the existing floor is not reinforced concrete at least of minimum thickness (depending on model), an elevated pad is desired or multiple machines are to be installed, the following steps must be performed (refer to *Figures 18* through *35*):

- Cut a hole larger on all sides than the machine base through the existing floor, refer to *Table 2*.
- Excavate to a depth as indicated in *Table 2* from the top of the existing floor.
- If installing a foundation with elevated pad, prepare a form for the above-ground portion of the foundation. Verify that the top of the foundation is level. The height of the foundation pad must not exceed 8 inches (203 mm) above the existing floor.
- Backfill with clean fill dirt.
- Compact backfill, making sure to allow for correct concrete thickness.

Installation

6. Drill holes (refer to manufacturer's requirements for drill hole size) for the perimeter reinforcing bar at a depth of 2.5 inches (64 mm) into the existing floor. The reinforcing should be 12 inches (305 mm) on center each way around entire perimeter.
 7. Clean out debris from each reinforcing bar hole.
 8. Fill half the hole depth with acrylic adhesive.
 9. Using #4 (60 ksi) reinforcing bar, tie new pad to existing floor making sure to tie reinforcing bars at the intersections and using proper reinforcing bar supports to hold bars at the proper depth in the pad.
 10. Allow adhesive around reinforcing bar to cure properly, refer to adhesive manufacturer for recommended cure times.
 11. Completely fill with 3500 psi minimum concrete up to the existing foundation level plus any added level (maximum of 8 inch [203 mm]) for the desired elevated pad. The concrete must be poured so that the entire foundation and pad cures as one piece.
 12. Allow concrete to cure, refer to manufacturer's recommended cure times.
 13. Using a mounting bolt template, elevated base frame or the machine base, mark where the holes should be drilled to mount the machine.
- NOTE: As an alternate method, cast in the Grade 5 (minimum SAE rating), 5/8 inches (16 mm) for 20 - 60 pound models and 3/4 inch (19 mm) for 80 - 125 pound models anchor bolts as the concrete is poured, refer to *Figure 37*. Ensure that the bolt threads extend a minimum of 2.5 inches (64 mm) above floor level and a minimum of 3.5 inches (89 mm) for 20 - 60 pound models and 5.5 inches (140 mm) for 80 - 125 pound models if the bolt is embedded in concrete.**
14. Proceed to *Machine Mounting and Grouting* section.

Single Machine Installation – 20 and 30 Pound Models (F and V-speed)

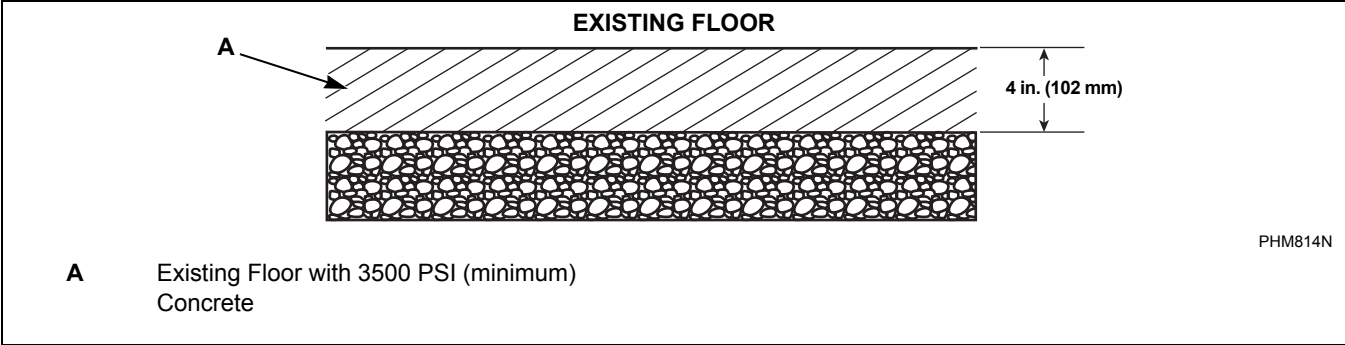

Figure 18

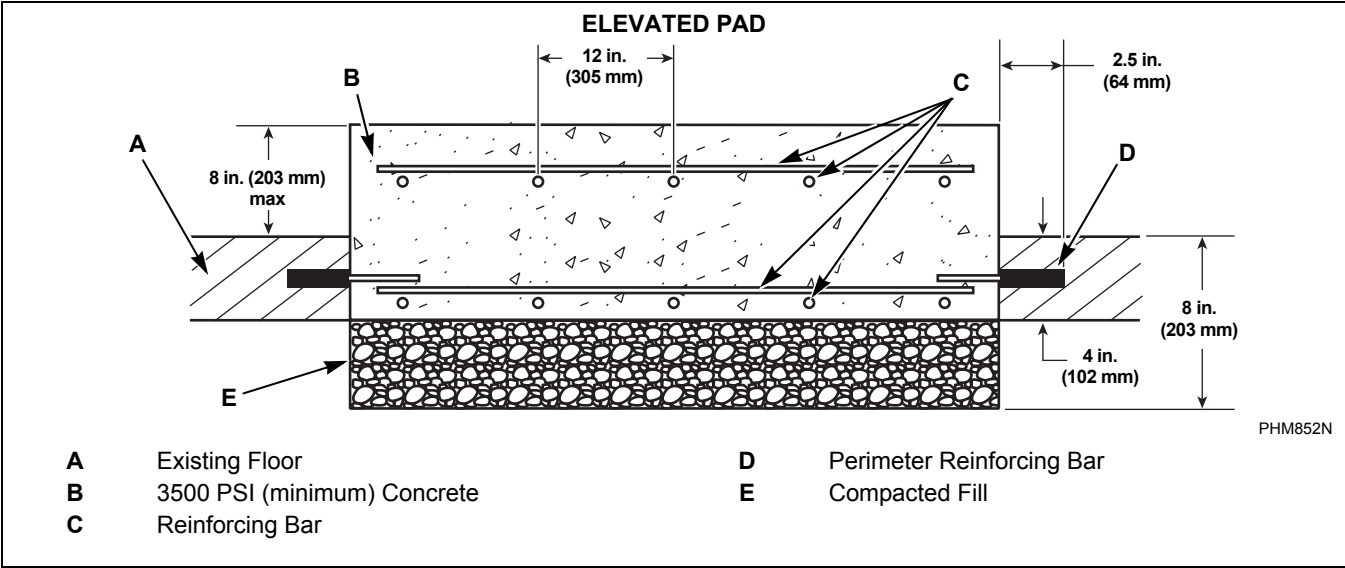

Figure 19

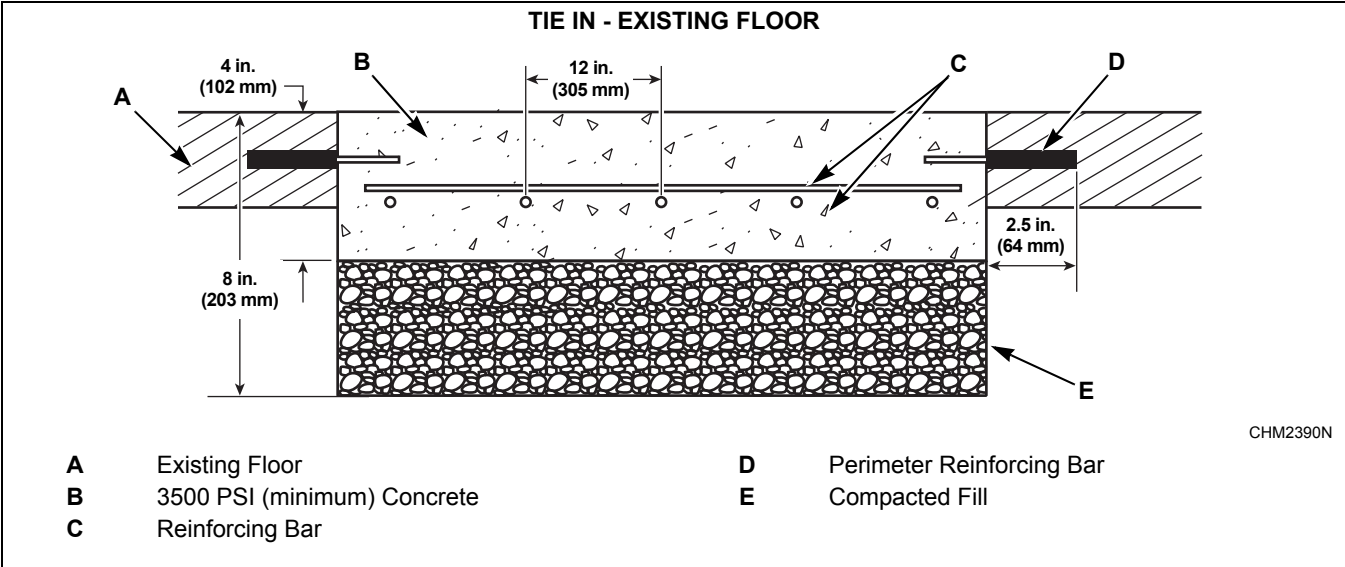

Figure 20

Installation

Single Machine Installation – 40 and 60 Pound Models (F-speed)

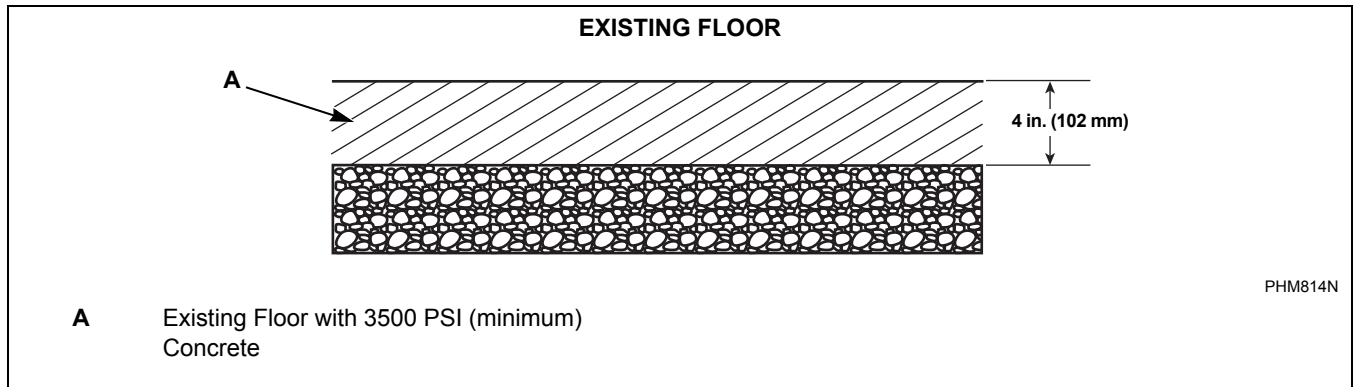

Figure 21

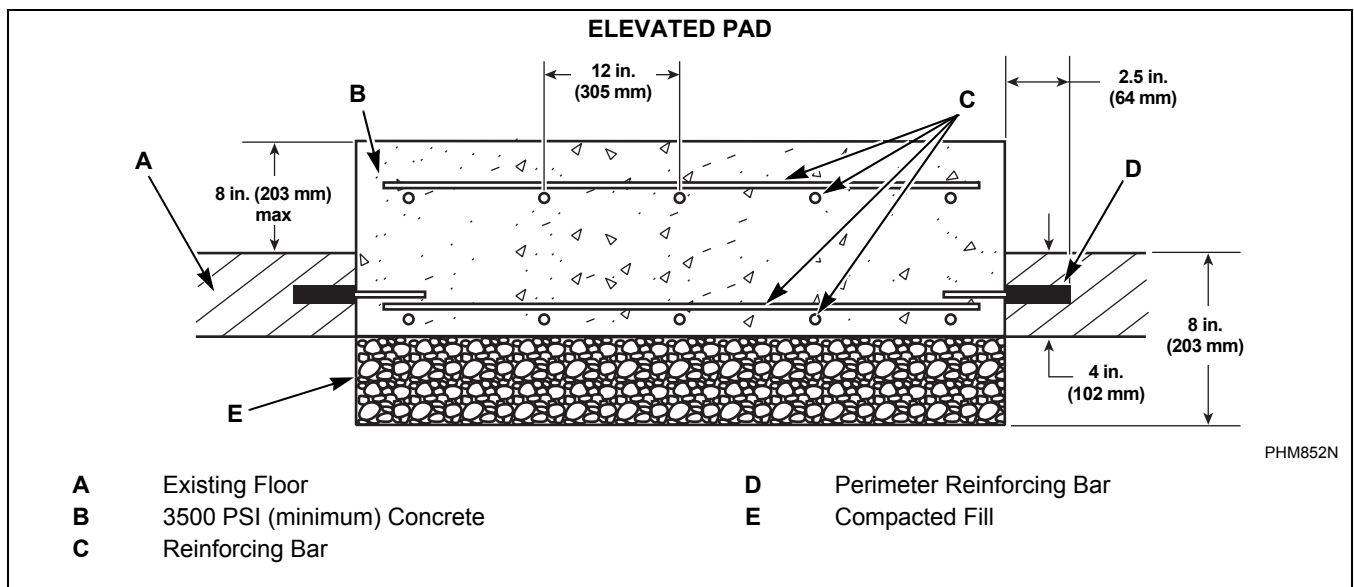

Figure 22

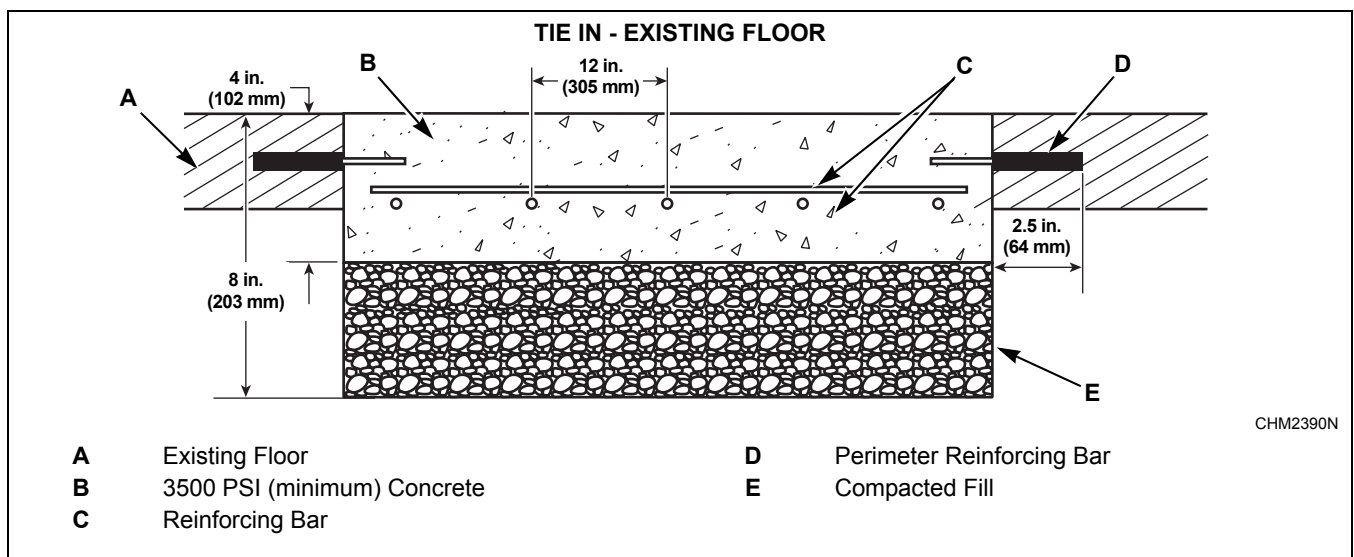

Figure 23

Single Machine Installation – 40 and 60 Pound Models (V-speed)

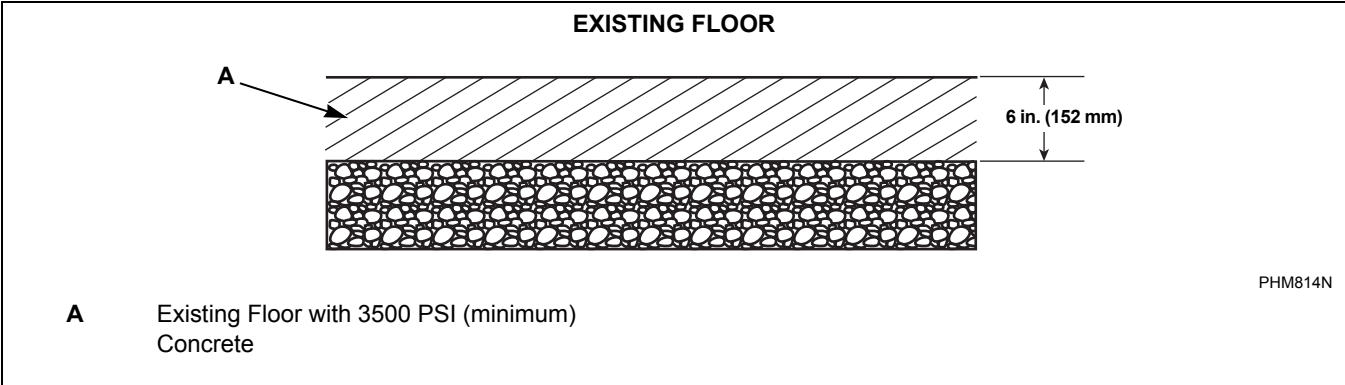

Figure 24

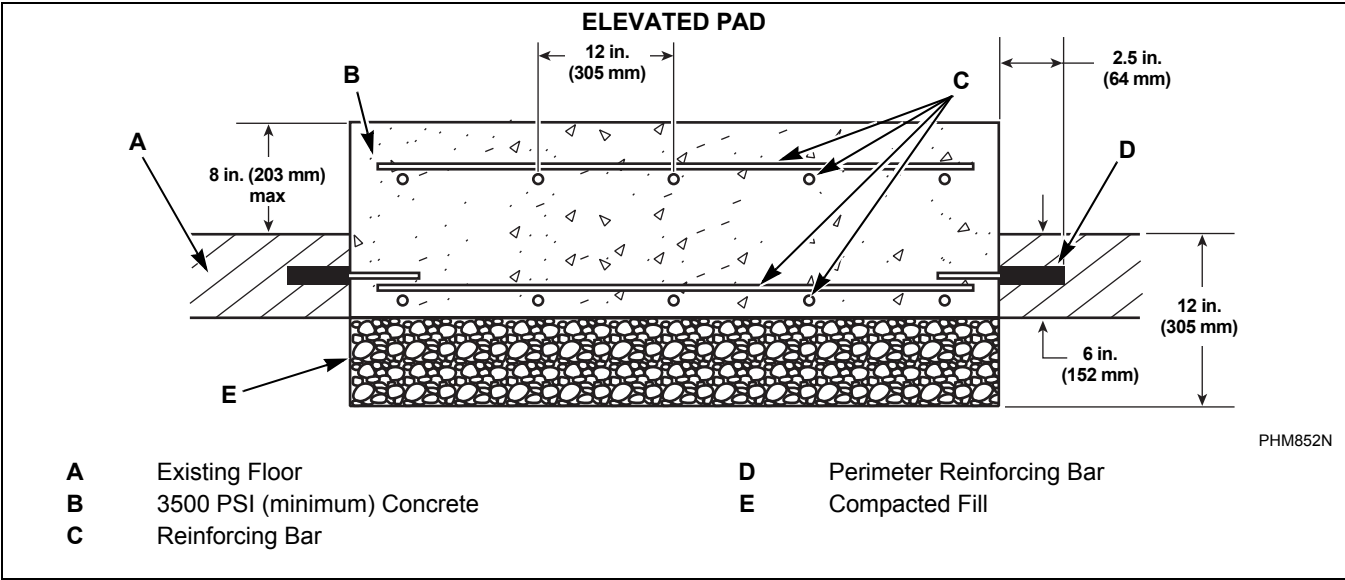

Figure 25

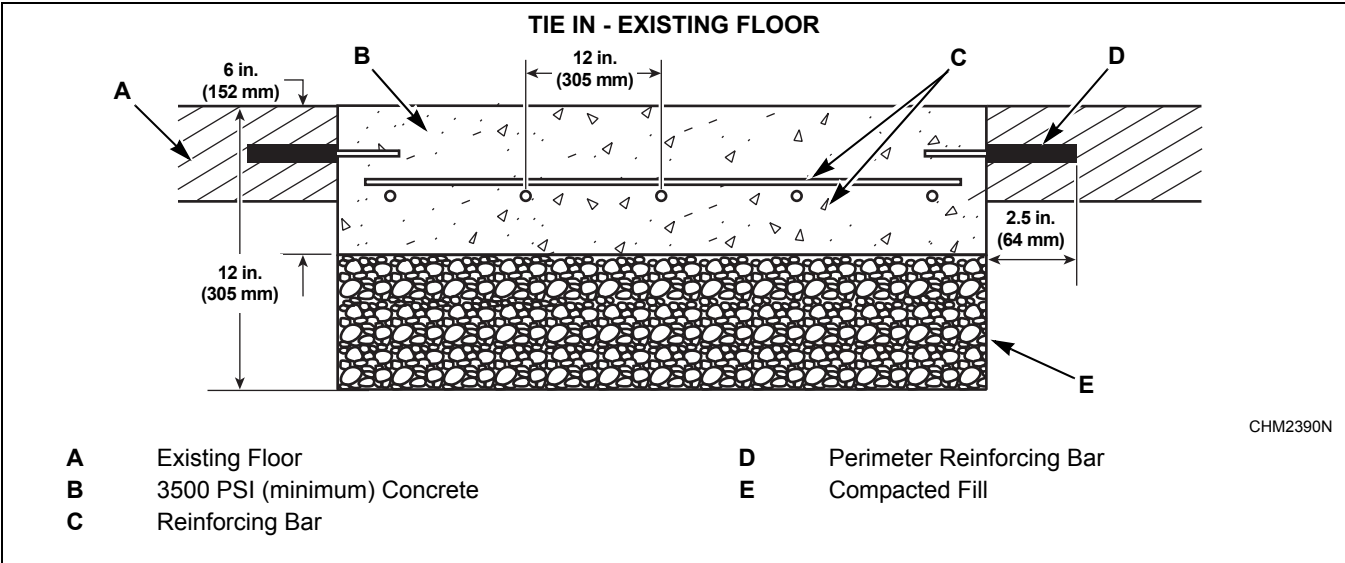

Figure 26

Installation

Single Machine Installation – 80 and 100 Pound Models (F-speed)

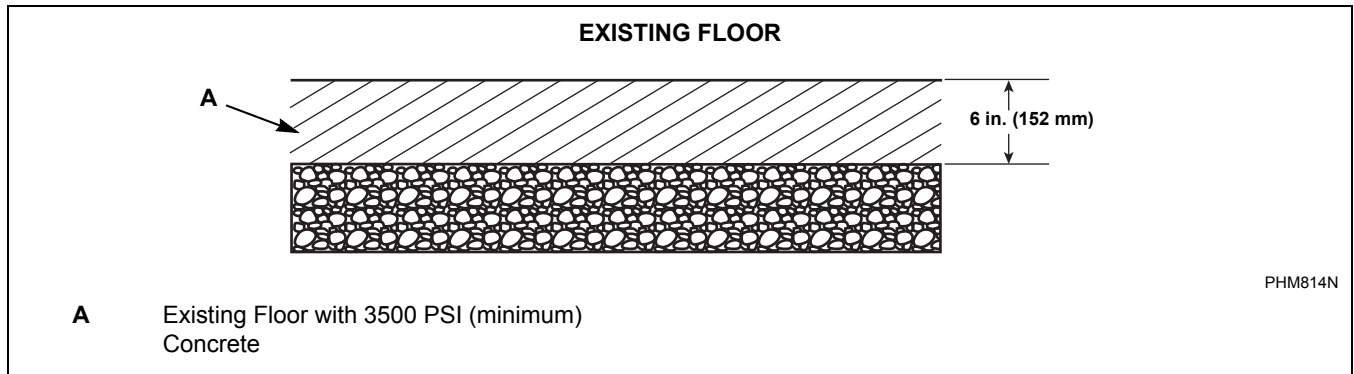

Figure 27

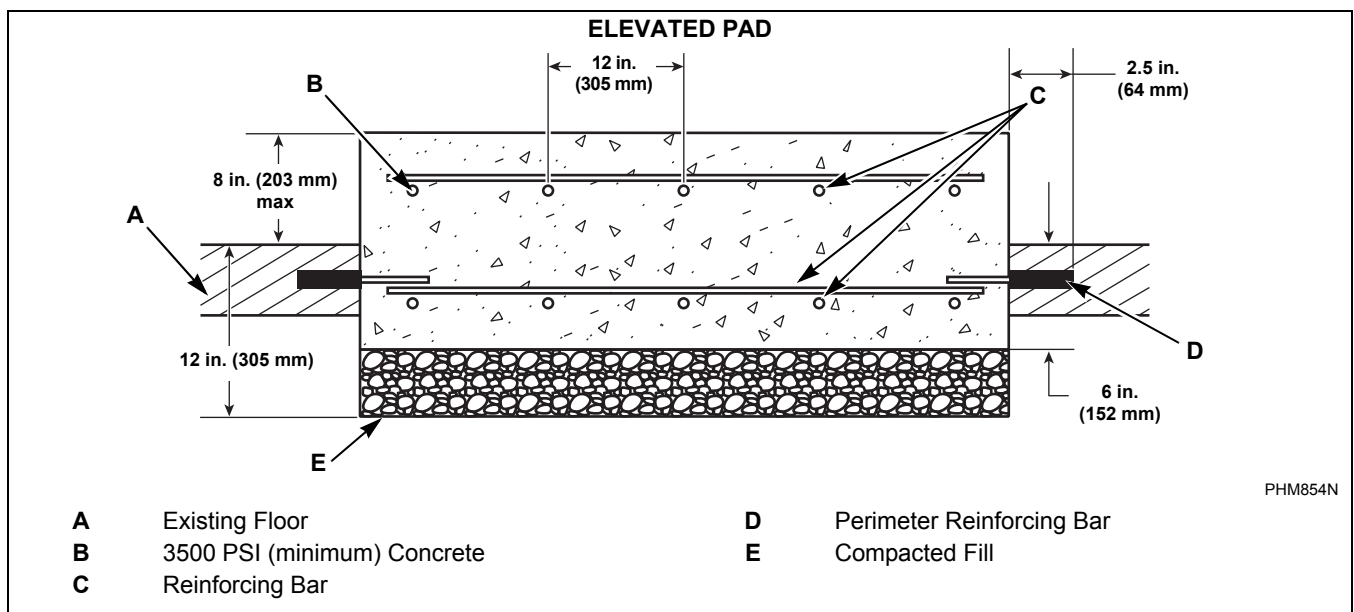

Figure 28

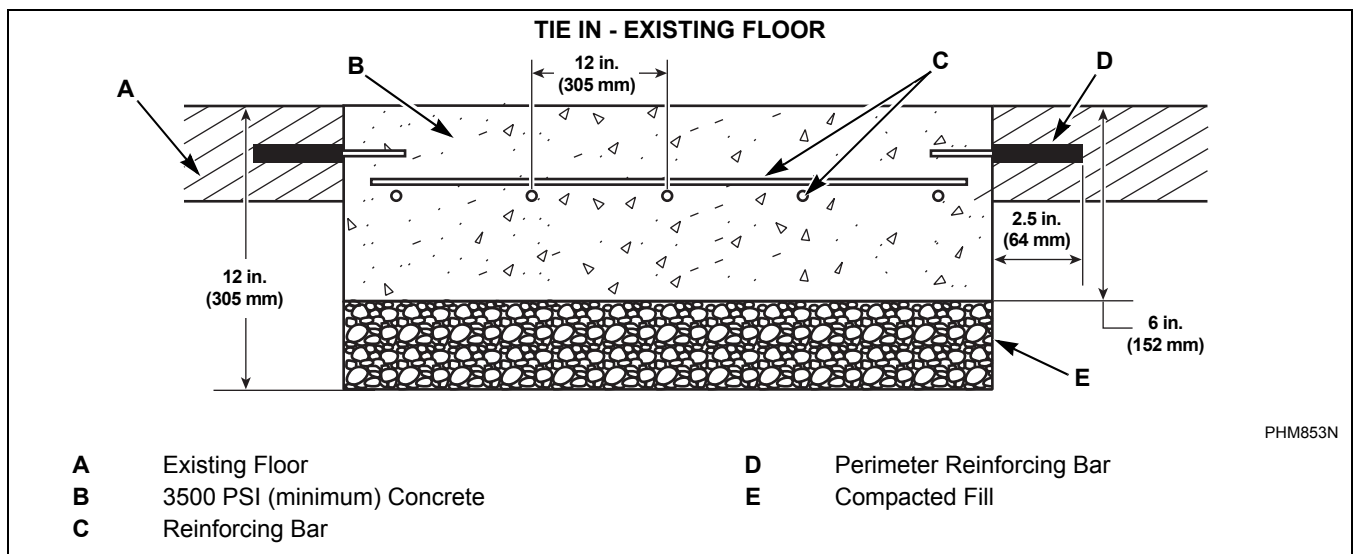

Figure 29

Single Machine Installation – 80 and 100 Pound Models (V-speed)

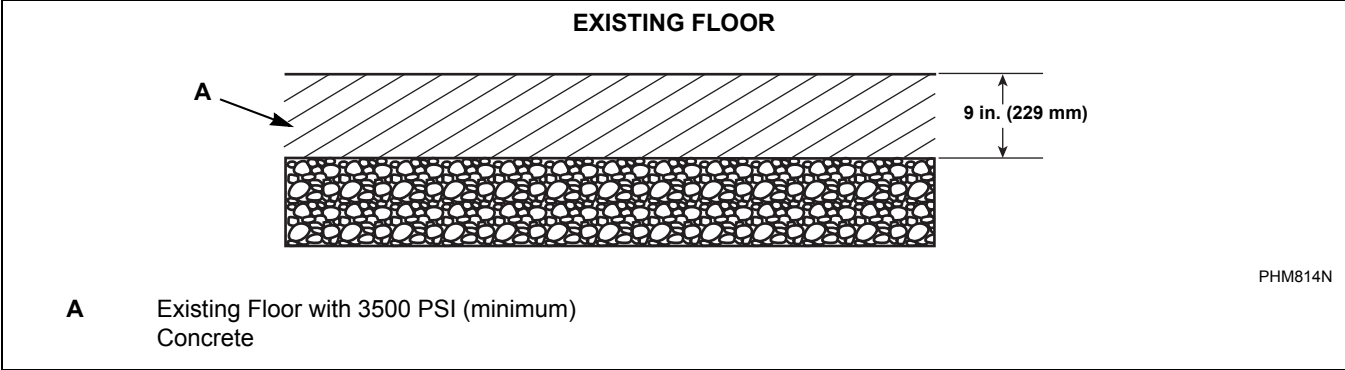

Figure 30

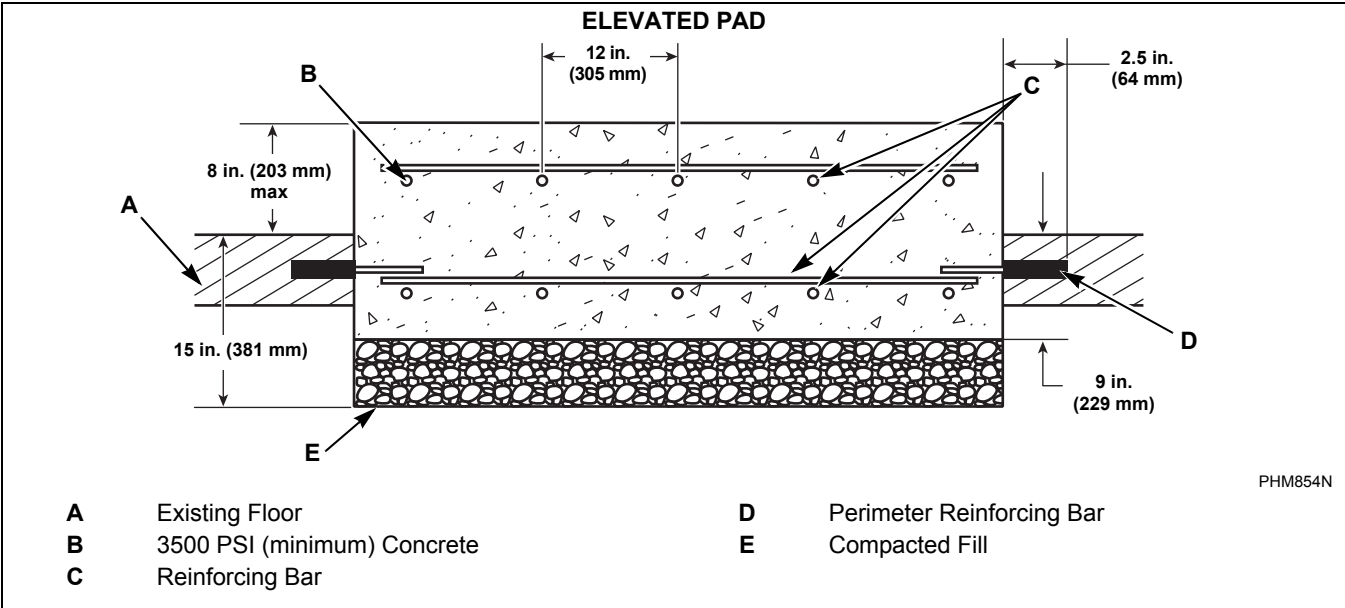

Figure 31

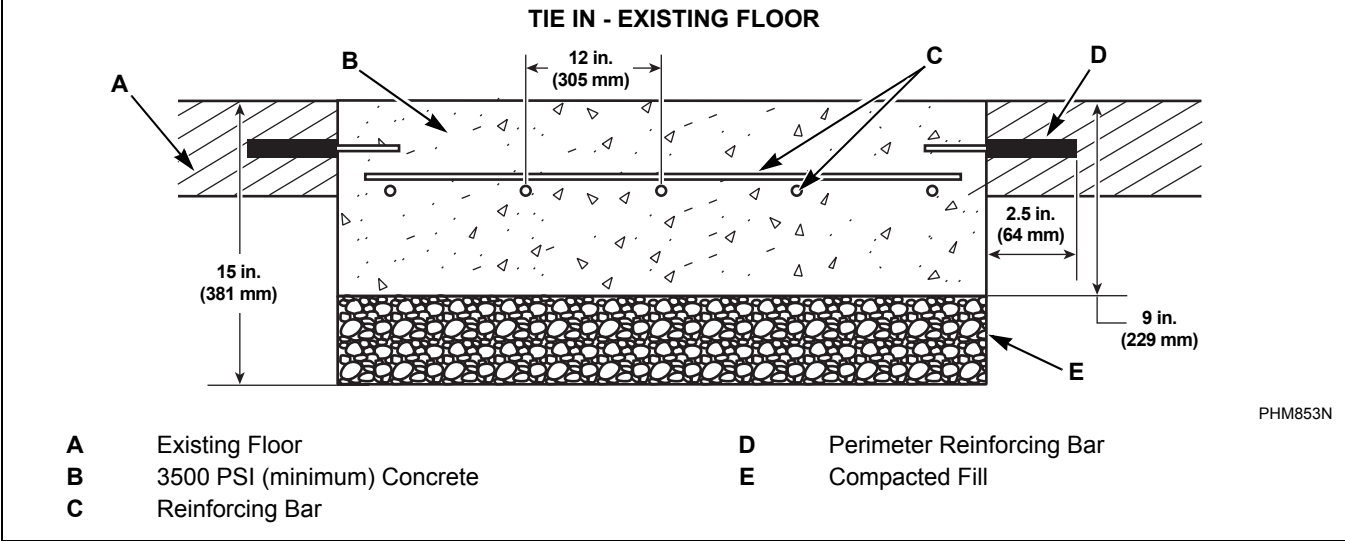

Figure 32

Installation

**Single Machine Installation –
125 Pound Models (V-speed)**

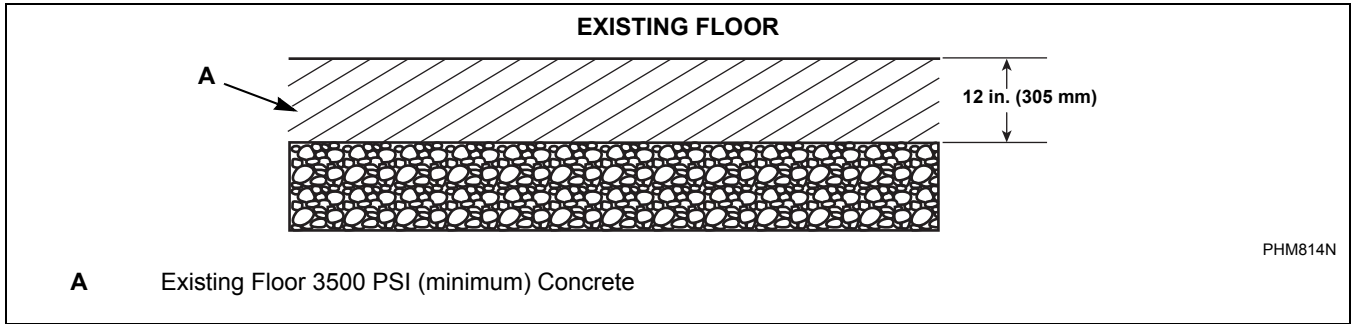

Figure 33

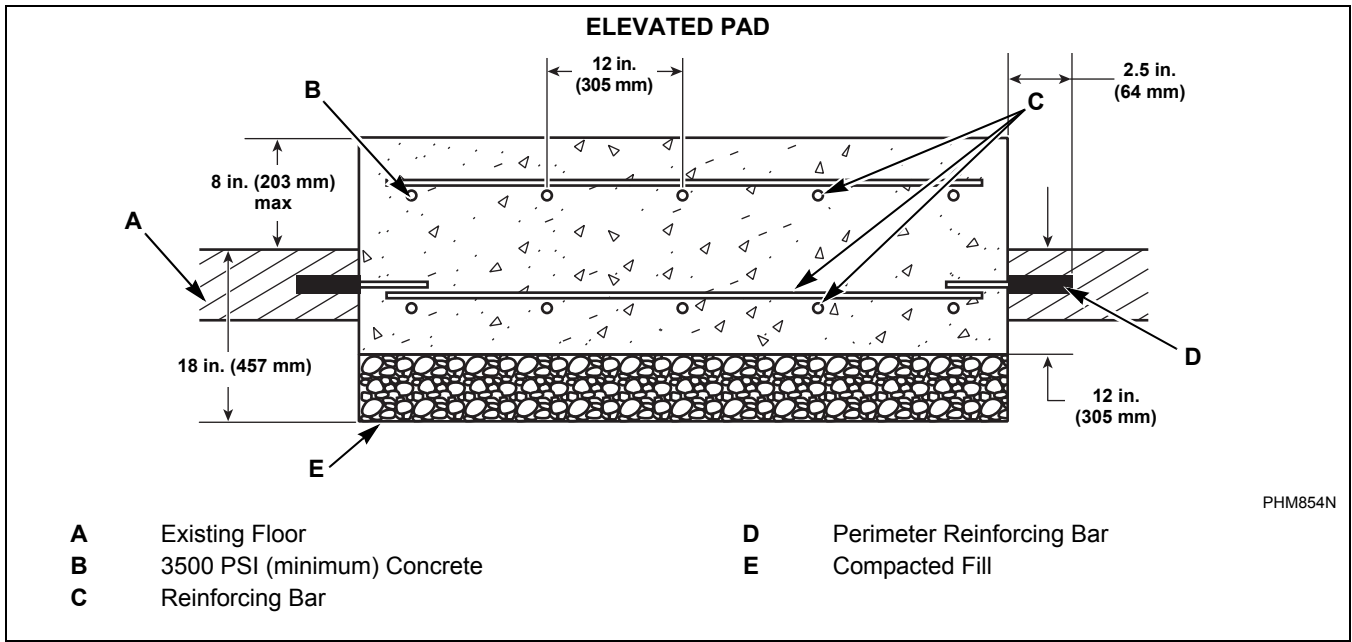

Figure 34

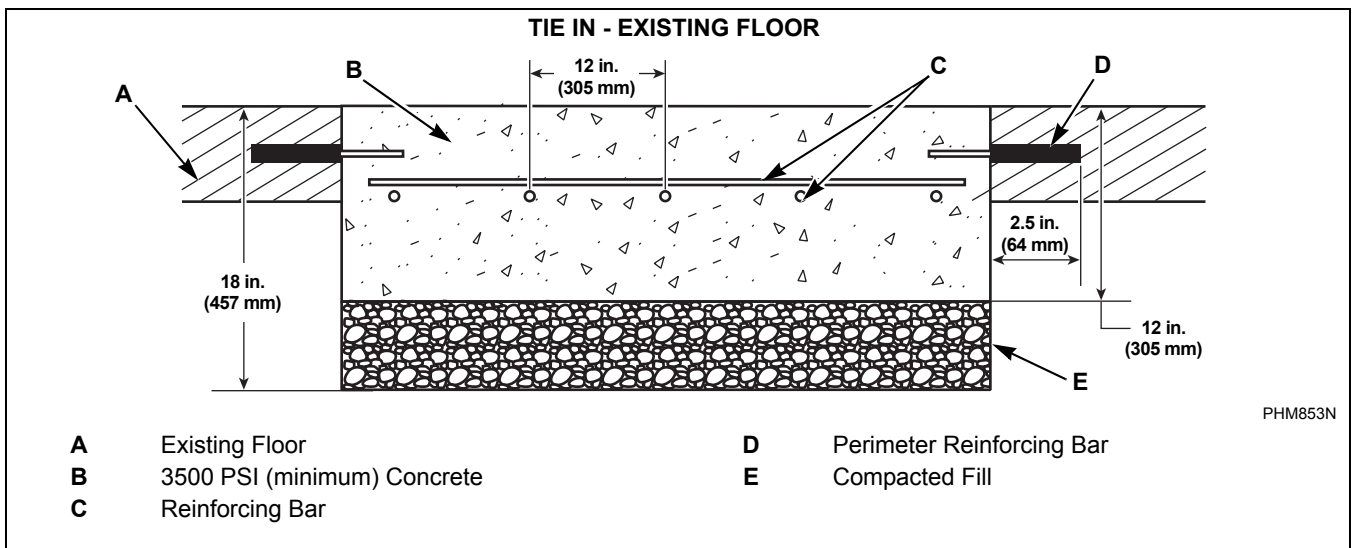

Figure 35

Machine Mounting and Grouting

NOTE: After the concrete has cured completely and the cast-in-place method was used, refer to *Figure 37* and proceed to step 7. If acrylic adhesive anchors are desired, refer to *Figure 36* and proceed with step 1 after concrete has cured completely.

1. Refer to *Table 3* to set the drill depth gauge.

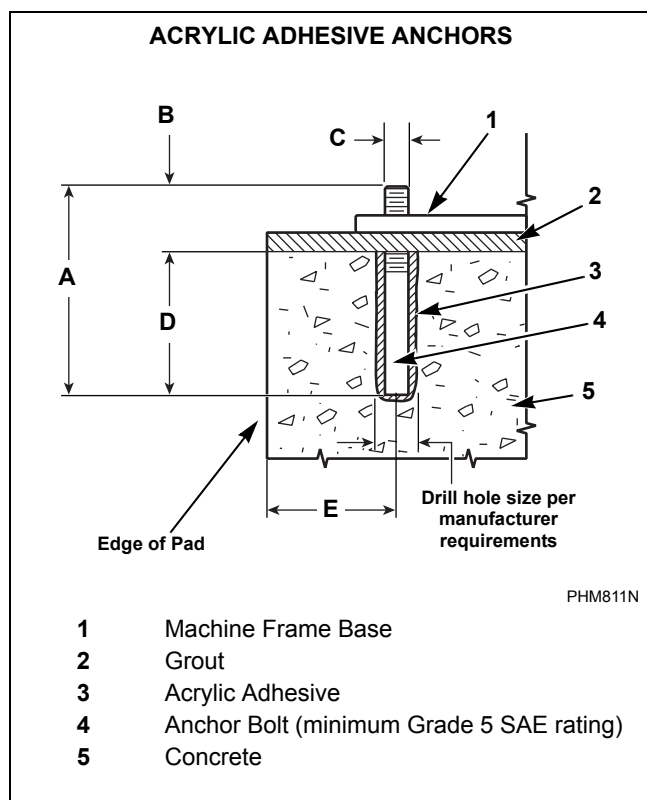

Figure 36

Minimum Anchoring Specifications					
		20-40	60	80-100	125
	Number of Bolts	4 or 6*	6	6	10
A	Bolt Length	6 in. (152 mm)	6 in. (152 mm)	8.5 in. (216 mm)	8 in. (203 mm)
B	Thread Extension	2.5 in. (64 mm)	2.5 in. (64 mm)	2.5 in. (64 mm)	2.5 in. (64 mm)
C	Bolt Diameter	5/8 in. (16 mm)	5/8 in. (16 mm)	3/4 in. (19 mm)	3/4 in. (19 mm)
D	Embedment Depth	3.5 in. (89 mm)	3.5 in. (89 mm)	6 in. (152 mm)	5.5 in. (127 mm)
E	Distance from Bolt Center to Edge of Concrete Pad	6 in. (152 mm)	6 in. (152 mm)	6 in. (152 mm)	6 in. (152 mm)

* On 20-40 pound models, the four (4) corner bolts are required and the two (2) center bolts are optional when mounting a machine or elevated base frame to floor.

Table 3

2. Drill the holes to the set depth.
3. Use compressed air or squeeze bulb to clean out debris from each hole.
4. Fill half the hole depth with an industry-accepted adhesive anchoring system.
5. Insert anchor bolt until it reaches the bottom and a minimum of 2.5 in. (64 mm) extends above surface and a minimum of 3.5 in. (89 mm) for 20-60 pound models, 6 in. (127 mm) for 80-100 pound models or 5.5 in. (127 mm) for 125 pound models is embedded in concrete.
6. Ensure all air pockets are removed from adhesive surrounding the bolt.
7. Allow adhesive around bolt to cure completely.

IMPORTANT: Refer to bolt manufacturer's recommended adhesive cure times.

Installation

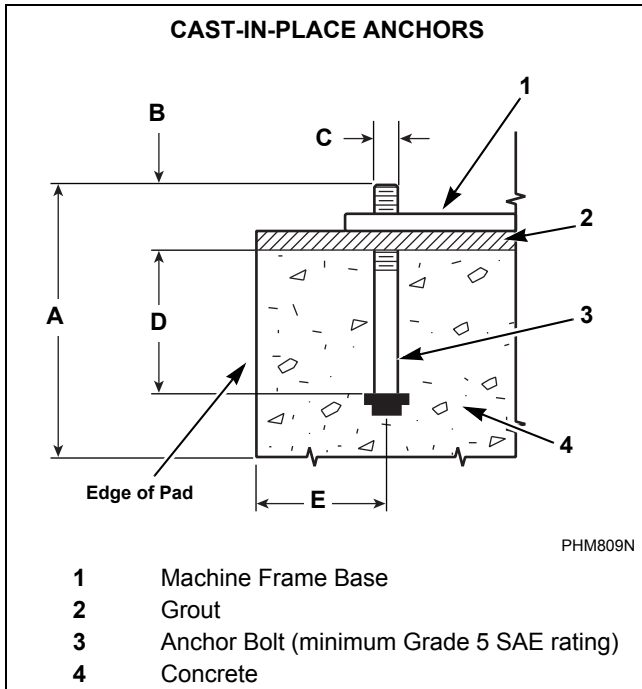

Figure 37

8. Remove shipping materials and place the machine or elevated base frame carefully over the bolts.

NOTE: Never attempt to lift the machine by the door handle or by pushing on the cover panels. Always insert a pry bar or other lifting device under the bottom frame of the machine to move it.

IMPORTANT: DO NOT install 80 pound or larger machines on an elevated metal base frame.

9. Raise and level the machine or elevated base frame 0.5 inch (1.27 cm) off the floor on four corners, using spacers such as nut fasteners.

	WARNING
<p>Crush hazard. To avoid personal injury and/or property damage, do not tip the machine more than 25 degrees in any direction.</p>	
W793	

10. Completely fill the space between the elevated base frame or machine base and the floor with a good quality **non-shrinking machinery precision grout** to ensure a stable installation. Grout completely under frame. Remove front panel and back panel to gain access to **entire perimeter of base plates**. Force grout under base until all voids are filled.

IMPORTANT: Minimum Grade 5, SAE rating, flat washers and minimum Grade 5, SAE rating, serrated hex flange locknuts are the recommended hardware for anchoring machine or elevated base frame to anchor bolts.

11. Position the flat washers and locknuts on the anchor bolts and finger-tighten to machine base or elevated base frame.
12. Allow machine grout to set, but not cure.
13. Remove the spacers carefully, allowing the machine base or elevated base frame to settle into the wet grout.

NOTE: If installing a 20 through 60 pound model directly to finished floor, wait until grout is completely cured and skip to Step 18. If installing on elevated base frame, proceed to Step 14.

20-60 Pound Models

14. After the grout is completely cured, position the machine over the elevated base frame.
15. Align the mounting holes on the machine with the corresponding holes on the elevated base frame.
16. Install a bolt, flat washer and locknut in each mounting hole.
17. Hand tighten each nut.
 - a. Tighten the two rear nuts two turns.
 - b. Tighten the two front nuts two turns.
 - c. Tighten the two middle nuts firmly.
18. Torque all the locknuts to 90 ft.-lbs. – one after the other – until all are tightened evenly and the machine is fastened securely to the elevated base frame or floor.

80 Pound and Larger Models

19. After the grout is completely cured, torque the locknuts to 160 ft.-lbs – one after the other – until all are tightened evenly and the machine is fastened securely to the floor.

IMPORTANT: Refer to recommended grout cure times from manufacturer before torquing locknuts.

NOTE: Check and retighten the locknuts after five to ten days of operation and every month thereafter.

Floor Load Data								
Specification	20	30	40	60	80	100	125	
Static floor load, lbs. (kN)	420 (1.87)	570 (2.54)	700 (3.11)	940 (4.18)	1550 (6.89)	1670 (7.51)	2795 (12.43)	
Static pressure, lbs.-ft ² (kN-m ²)	96 (4.60)	99 (4.74)	100 (4.79)	106 (5.08)	137 (6.56)	147 (7.04)	163 (7.80)	
Dynamic floor load, lbs. (kN)	420 (1.86)	630 (2.80)	840 (3.74)	1260 (5.61)	1680 (7.48)	1680 (7.48)	2814 (12.52)	
Dynamic floor pressure, lbs.-ft ² (kN-m ²)	96 (4.60)	109 (5.22)	119 (5.70)	143 (6.85)	149 (7.13)	149 (7.13)	165 (7.9)	
Dynamic load frequency, Hz	F-speed	9.7	9.0	8.6	8.1	7.4	7.4	N/A
	V-speed	13.7	12.8	12.2	11.4	10.4	9.5	8.3
Maximum moment about machine base, lbs.-ft. (kN-m)	805 (1.09)	1260 (1.71)	1820 (2.47)	2770 (3.76)	4330 (5.87)	4330 (5.87)	9398 (12.74)	
Maximum vertical load, lbs. (kN)	795 (3.54)	1150 (5.12)	1470 (6.54)	2080 (9.25)	3050 (13.57)	3140 (13.82)	5365 (23.86)	

Table 4

Installation

Drain Connection

IMPORTANT: Machine must be installed in accordance with all local codes and ordinances.

All drain systems must be vented to prevent an air lock or siphoning.

Use the supplied black rubber adapter and clamps to transition from the machine drain outlet to the 2 inches (51 mm) schedule 40 PVC plumbing (20 and 30 models) and the 3 inches (76 mm) schedule 40 PVC plumbing (40, 60, 80, 100 and 125 models).

If proper drain size is not available or practical, a surge tank is required. A surge tank along with a sump pump should be used when gravity drainage is not possible.

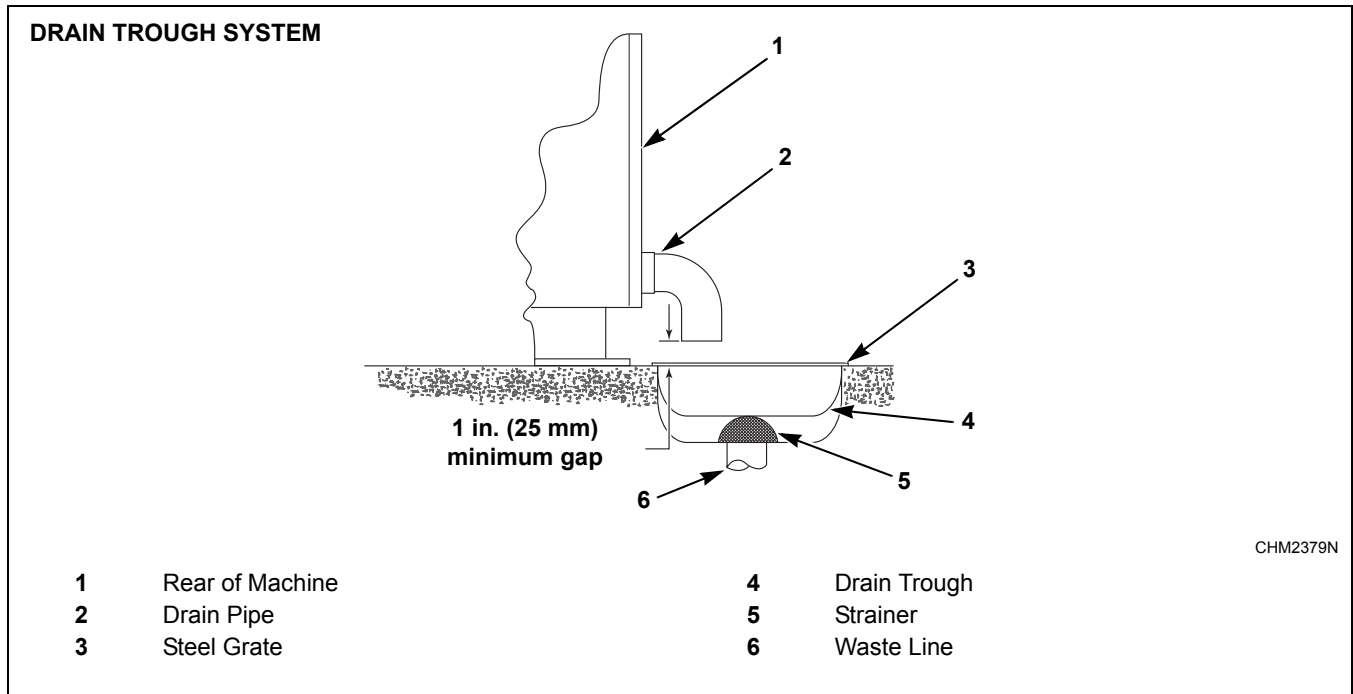

Figure 38

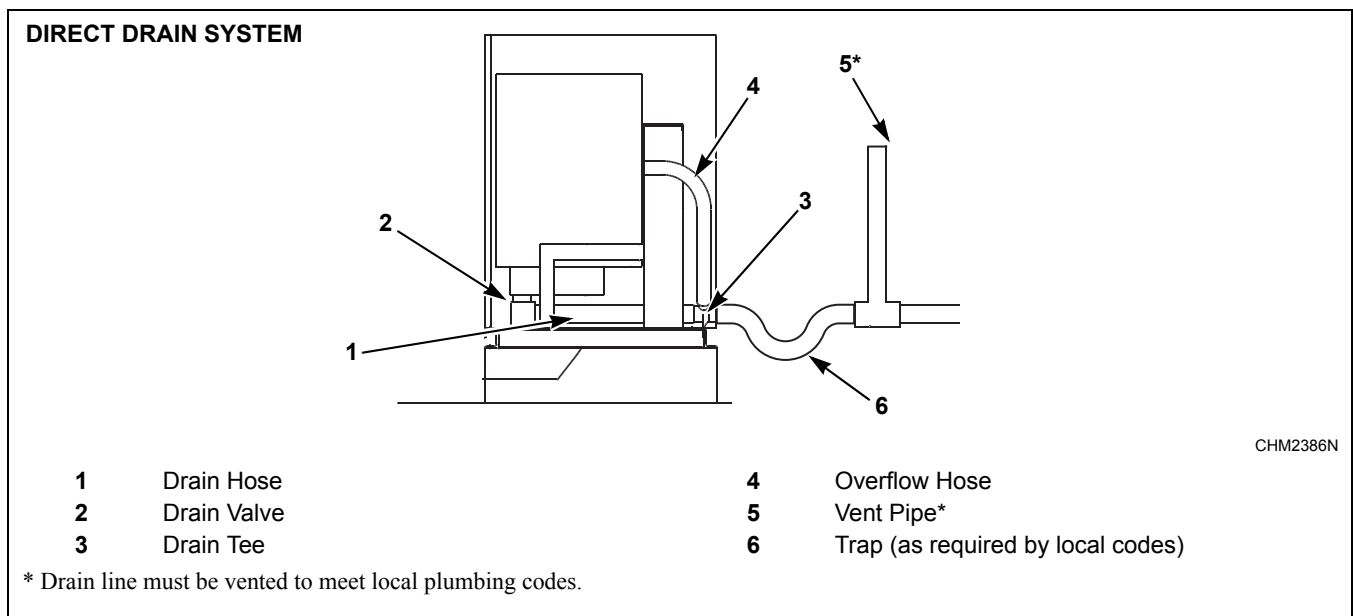

Figure 39

IMPORTANT: Increasing the drain hose length, installing elbows, or causing bends will decrease drain flow rates and increase drain times, impairing machine performance.

NOTE: Installation of additional machines will require larger drain connections. Refer to *Table 6*.

Drain Information							
	20	30	40	60	80	100	125
Drain connection size	2 in. (51 mm)	2 in. (51 mm)	3 in. (76 mm*)	3 in. (76 mm*)	3 in. (76 mm*)	3 in. (76 mm*)	3.5 in. (89 mm*)
Overflow drain connection size	1.5 in. (457 mm)	1.5 in. (457 mm)	1.5 in. (457 mm)	1.5 in. (457 mm)	2.25 in. (686 mm)	2.25 in. (686 mm)	2.25 in. (686 mm)
Number of drain outlets	1	1	1	1	1	1	1
Drain flow capacity	25 gal/min (95l/min)	30 gal/min (114l/min)	40 gal/min (151l/min)	50 gal/min (189l/min)	55 gal/min (208l/min)	55 gal/min (208l/min)	70 gal/min (265l/min)
Recommended drain pit size	2.0 ft ³ (57l)	2.5 ft ³ (71l)	3.5 ft ³ (128l)	5.7 ft ³ (99l)	8.0 ft ³ (221l)	9.5 ft ³ (269l)	13 ft ³ (368l)

* Also works with 3 in. OD PVC pipe if connected to inside of drain tee connector.

Table 5

Drain Line Sizing Minimum Drain ID					
Model	Number of Machines				
	1	2	3	4	5
20	2 in. (51 mm)	3 in. (76 mm)	3 in. (76 mm)	4 in. (102 mm)	4 in. (102 mm)
30	2 in. (51 mm)	3 in. (76 mm)	3 in. (76 mm)	4 in. (102 mm)	4 in. (102 mm)
40	3 in. (76 mm)	4 in. (102 mm)	4 in. (102 mm)	4 in. (102 mm)	6 in. (152 mm)
60	3 in. (76 mm)	4 in. (102 mm)	4 in. (102 mm)	4 in. (102 mm)	6 in. (152 mm)
80 - 125	4 in. (102 mm)	6 in. (152 mm)	6 in. (152 mm)	8 in. (203 mm)	8 in. (203 mm)

Table 6

Water Connection Requirements

	WARNING
<p>To prevent personal injury, avoid contact with inlet water temperatures higher than 125° Fahrenheit (51° Celsius) and hot surfaces.</p>	
W748	

The maximum water inlet temperature for vended models is 125°F (51°C) and the recommended maximum water inlet temperature for on-premises models is 150°F (66°C).

Connections should be supplied by a hot and a cold water line of at least the sizes shown in *Table 8*. Installation of additional machines will require proportionately larger water lines.

To connect water service to a machine with hoses, use the following procedure:

1. Before installing hoses, flush the building’s water system at the machine connection valves for at least two (2) minutes.
2. Check filters in the machine’s inlet hoses for proper fit and cleanliness before connecting.
3. Hang hoses in a large loop; do not allow them to kink.

If additional hose lengths are needed or using hoses other than those supplied by manufacturer, flexible hoses with screen filters are required.

Cabinet Hardmount Water Supply Information		
	Model	Requirement
Water Inlet Connection size, in. BSP (mm)	20 - 125	3/4 (19)
Thread pitch, GHT (BSPP)	20 - 125	3/4 x 11.5 (3/4 x 14)
Number of water inlets	20 - 125	2
Number of auxillary water inlets	80 - 100	2
Recommended pressure, psi (bar)	20 - 125	20 - 85 (1.4 - 5.7)
Inlet flow capacity per inlet, gal-min (at 85 psi)/l-min (at 5.5 bar)	20 - 100	5.2 (20)
	80 - 100 (Auxillary water inlets)	4.0 (15)
	125	50 (189)

Table 7

Water Supply Line Sizing			
Model	Number of Machines	Supply Line Size	
		Main	Hot/Cold
20 – 100	1	.75 in. (19 mm)	.75 in. (19 mm)
	2	1 in. (25 mm)	.75 in. (19 mm)
	3	1.25 in. (32 mm)	1 in. (25 mm)
	4	1.5 in. (38 mm)	1 in. (25 mm)
125	1	1.5 in. (38 mm)	1 in. (25 mm)
	2	2 in. (50 mm)	1.5 in. (38 mm)
	3	2 in. (50 mm)	2 in. (50 mm)
	4	2.5 in. (70 mm)	2 in. (50 mm)

Table 8

Suitable air cushions (risers) should be installed in supply lines to prevent “hammering.” Refer to *Figure 40*.

Alliance Laundry Systems, LLC ranges of front loading commercial clothes washing machines have solenoid valves at the inlets. The water supply to the washing machines is supplied with an AB air gap between the soap tray and the drum. Minimum and maximum working pressure 1.4 bar and 8.3 bar. The machines are supplied with approved inlet hoses with a maximum inlet dimension of 0.50 in. (12.6 mm) (ID).

NOTE: This machine has a fluid category 5 backflow prevention device built in between the soap tray and drum.

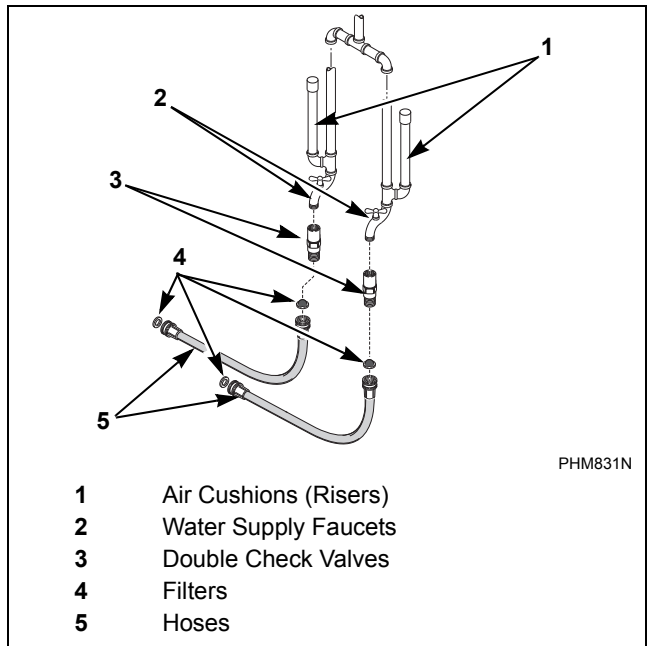





Figure 40

Electrical Installation Requirements

IMPORTANT: Electrical ratings are subject to change. Refer to nameplate for electrical ratings information specific to your machine.

	DANGER
<p>Electrical shock hazard will result in death or serious injury. Disconnect electric power and wait five (5) minutes before servicing.</p>	
W810	

	WARNING
<p>Dangerous voltages are present inside the machine. Only qualified personnel should attempt adjustments and troubleshooting. Disconnect power from the machine before removing any cover and guards, and before attempting any service procedures.</p>	
W736	

	WARNING
<p>Hazardous Voltage. Can cause shock, burn or death. Verify that a ground wire from a proven earth ground is connected to the lug near the input power block on this machine.</p>	
W360	

Electrical connections are made at the rear of the machine. The machine must be connected to the proper electrical supply shown on the nameplate on the rear of the machine, using copper conductors only.

IMPORTANT: Alliance Laundry Systems warranty does not cover components that fail as a result of improper input voltage.

Make sure the correct transformer jumper (208 Volt or 240 Volt) is in place. Refer to the “optional” Electrical Service Conversion label located on the back of the machine near the nameplate. Refer to *Figure 41*.

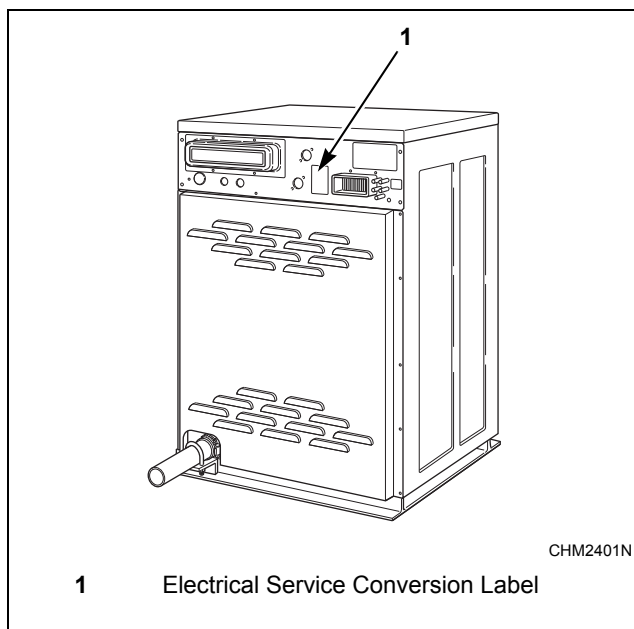

Figure 41

Machines are equipped with an AC inverter drives requiring a clean power supply, free from voltage spikes and surges. Use voltage monitor to check incoming power.

Installation

Input Power Conditioning

The drive is suitable for direct connection to input power within the rated voltage of the drive. Listed in *Table 9* are certain input power conditions which may cause component damage or reduction in product life. If any of the conditions exist, install one of the devices listed under the *Corrective Action*.

IMPORTANT: Only one device per branch circuit is required. It should be mounted closest to the branch and sized to handle the total current of the branch circuit.

Input Power Condition	Possible Corrective Action(s)
Low Line impedance (less than 1% line reactance)	<ul style="list-style-type: none"> • Install Line Reactor • Isolation Transformer
Greater than 120 kVA supply transformer	
Line has power factor correction capacitors	<ul style="list-style-type: none"> • Install Line Reactor • Isolation Transformer
Line has frequent power interruptions	
Line has intermittent noise spikes in excess of 6000V (lightning)	
Phase to ground voltage exceeds 125% of normal line to line voltage	<ul style="list-style-type: none"> • Remove MOV jumper to ground • Install Isolation Transformer with grounded secondary (if necessary)
Ungrounded distribution system	
240V open delta configuration (stinger leg)*	<ul style="list-style-type: none"> • Install Line Reactor

* For drives applied on an open delta with a middle phase grounded neutral system, the phase opposite the phase that is tapped in the middle to the neutral or earth is referred to as the “stinger leg,” “high leg,” “red leg,” etc. This leg should be identified throughout the system with red or orange tape on the wire at each connection point. The stinger leg should be connected to the center Phase B on the reactor.

Table 9

Input Voltage Requirements

For voltages above or below listed specifications, contact your power company or local electrician.

If machine is intended for four-wire service, a neutral leg must be provided by power company.

If a delta supply system is used on a four-wire model, connect high leg to L3.

IMPORTANT: Improper connections will result in equipment damage and will void warranty.

	DANGER
<p>Electrical shock hazard will result in death or serious injury. Disconnect electric power and wait five (5) minutes before servicing.</p>	
W810	

	DANGER
<p>Hazardous Rotation Speed. Will cause serious injury when controlling AC inverter drive with a parameter unit, safety features are bypassed allowing basket to rotate at high speeds with the door open. Place large sign on front of machine to warn people of imminent danger.</p>	
W361	

Circuit Breakers and Quick Disconnects

Single-phase machines require a single-phase inverse-time circuit breaker. Three-phase machines and variable-speed machines require a separate, three-phase inverse-time circuit breaker to prevent damage to the motor by disconnecting all legs if one should be lost accidentally. Refer to *Table 10* through *Table 23* in this section for model-specific circuit breaker requirements.

IMPORTANT: All quick disconnects should comply with the specifications. DO NOT use fuses instead of circuit breakers.

Connection Specifications

IMPORTANT: Connection must be made by a qualified electrician using wiring diagram provided with machine, or according to accepted European Union standards.

Connect machine to an individual branch circuit not shared with lighting or other equipment. Shield connection in a liquid-tight or approved flexible conduit. Copper conductors of correct size must be installed in accordance with National Electric Code (NEC) or other applicable codes.

Use wire sizes indicated in the Electrical Specifications chart for runs up to 50 feet (15 m). Use next larger size for runs of 50 to 100 feet (15 to 30 m). Use two sizes larger for runs greater than 100 feet (30 m).

Single-Phase Connections

For single-phase input, connect L1, L2 and Ground and cap neutral as shown in *Figure 42*.

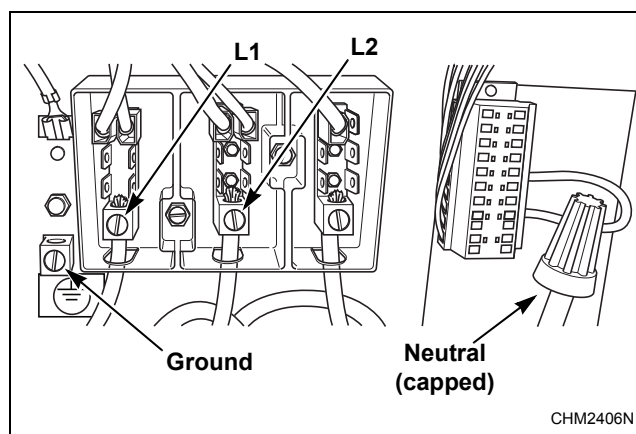

Figure 42

Installation

Three-Phase Connections

For three-phase input, connect L1, L2, L3 and Ground as shown in *Figure 43*.

IMPORTANT: If a stinger leg is used for three-phase input, it MUST be connected to L3.

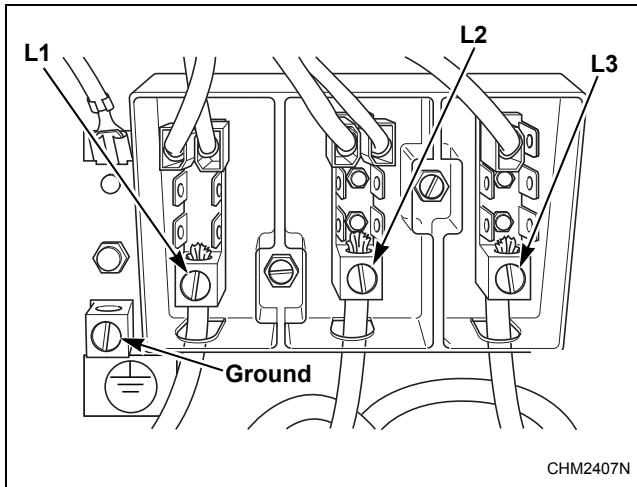

Figure 43

Grounding

For personal safety and proper operation, the machine must be grounded in accordance with state and local codes. If such codes are not available, grounding must conform to the National Electric Code, article 250 (current edition). The ground connection must be made to a proven earth ground, not to conduit or water pipes.

	WARNING
<p>Electrically heated machines DO NOT require dual power sources. Do not connect customer power or customer load to the Internal Load Distribution terminal block. Refer to the machine electrical schematic for details.</p>	
W759	

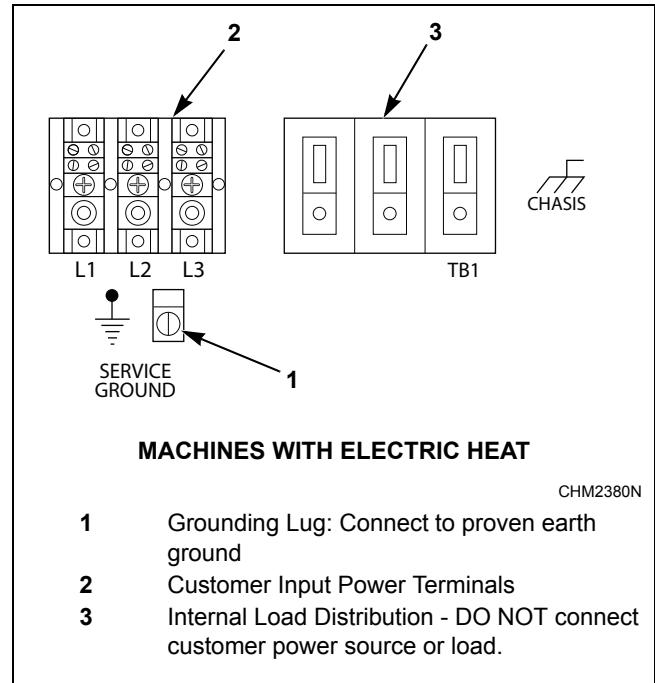

Figure 44

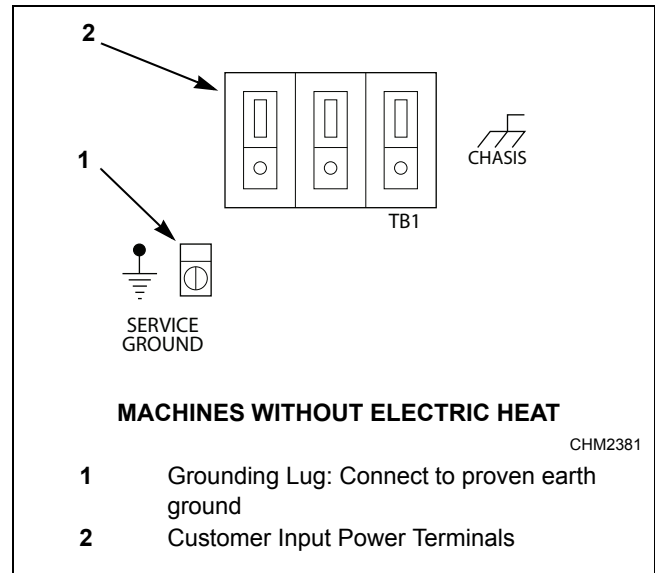

Figure 45

Machines can be converted for lower voltage operation and/or 50 Hz operation. Refer to conversion label by nameplate for details.

Phase Adder

IMPORTANT: Do not use a phase adder on any machine.

Thermal Overload Protector

For variable-speed machines, the AC drive provides overload protection for the drive motor.

Electrical Specifications

Non-CE Models

20 Pound Capacity Models												
Voltage Designation					Standard				Electric Heat			
Code	Voltage	Cycle	Phase	Wire	Full Load Amps	Circuit Breaker	AWG	mm ²	Full Load Amps	Circuit Breaker	AWG	mm ²
F-Speed Models												
B	120	60	1	2	7	15	14	2.5	N/A			
X	220 – 240	60	1/3	2/3	4/3	15	14	2.5	N/A			
Q	220 – 240	60	3	3	3	15	14	2.5	21	30	10	6.0
N	440 – 480	60	3	3	2	15	14	2.5	N/A			
P	380 – 415	50	3	3	2	15	14	2.5	13	15	14	2.5
V-Speed Models												
B	120	60	1	2	8	15	14	2.5	N/A			
X	220 – 240	60	1/3	2/3	4/3	15	14	2.5	N/A			
Q	220 – 240	60	3	3	3	15	14	2.5	21	30	10	6.0
N	440 – 480	60	3	3	2	15	14	2.5	N/A			
P	380 – 415	50	3	3	2	15	14	2.5	13	15	14	2.5

NOTE: Wire sizes shown are for copper, THHN, 90°C conductor per NEC article 310.

Table 10

30 Pound Capacity Models												
Voltage Designation					Standard				Electric Heat			
Code	Voltage	Cycle	Phase	Wire	Full Load Amps	Circuit Breaker	AWG	mm ²	Full Load Amps	Circuit Breaker	AWG	mm ²
F-Speed Models												
X	220 – 240	60	1/3	2/3	5/4	15	14	2.5	N/A			
Q	220 – 240	60	3	3	4	15	14	2.5	22	30	10	6.0
N	440 – 480	60	3	3	3	15	14	2.5	N/A			
P	380 – 415	50	3	3	3	15	14	2.5	13	15	14	2.5
V-Speed Models												
X	220 – 240	60	1/3	2/3	6/4	15	14	2.5	N/A			
Q	220 – 240	60	3	3	4	15	14	2.5	22	30	10	6.0
N	440 – 480	60	3	3	3	15	14	2.5	N/A			
P	380 – 415	50	3	3	3	15	14	2.5	13	15	14	2.5

NOTE: Wire sizes shown are for copper, THHN, 90°C conductor per NEC article 310.

Table 11

Installation

40 Pound Capacity Models												
Voltage Designation					Standard				Electric Heat			
Code	Voltage	Cycle	Phase	Wire	Full Load Amps	Circuit Breaker	AWG	mm ²	Full Load Amps	Circuit Breaker	AWG	mm ²
F-Speed Models												
X	220 – 240	60	1/3	2/3	6/4	15	14	2.5	N/A			
Q	220 – 240	60	3	3	4	15	14	2.5	42	50	8	10.0
N	440 – 480	60	3	3	3	15	14	2.5	22	30	10	6.0
P	380 – 415	50	3	3	3	15	14	2.5	25	30	10	6.0
V-Speed Models												
X	220 – 240	60	1/3	2/3	7/4	15	14	2.5	N/A			
Q	220 – 240	60	3	3	4	15	14	2.5	42	50	8	10.0
N	440 – 480	60	3	3	3	15	14	2.5	22	30	10	6.0
P	380 – 415	50	3	3	3	15	14	2.5	25	30	10	6.0

NOTE: Wire sizes shown are for copper, THHN, 90°C conductor per NEC article 310.

Table 12

60 Pound Capacity Models												
Voltage Designation					Standard				Electric Heat			
Code	Voltage	Cycle	Phase	Wire	Full Load Amps	Circuit Breaker	AWG	mm ²	Full Load Amps	Circuit Breaker	AWG	mm ²
F-Speed Models												
X	220 – 240	60	1/3	2/3	9/6	15	14	2.5	N/A			
Q	220 – 240	60	3	3	6	15	14	2.5	43	50	8	10.0
N	440 – 480	60	3	3	4	15	14	2.5	22	30	10	6.0
P	380 – 415	50	3	3	4	15	14	2.5	25	30	10	6.0
V-Speed Models												
X	220 – 240	60	1/3	2/3	10/6	15	14	2.5	N/A			
Q	220 – 240	60	3	3	6	15	14	2.5	43	50	8	10.0
N	440 – 480	60	3	3	4	15	14	2.5	22	30	10	6.0
P	380 – 415	50	3	3	4	15	14	2.5	25	30	10	6.0

NOTE: Wire sizes shown are for copper, THHN, 90°C conductor per NEC article 310.

Table 13

80 Pound Capacity Models												
Voltage Designation					Standard				Electric Heat			
Code	Voltage	Cycle	Phase	Wire	Full Load Amps	Circuit Breaker	AWG	mm ²	Full Load Amps	Circuit Breaker	AWG	mm ²
F-Speed Models												
X	220 – 240	60	1/3	2/3	12/8	15	14	2.5	N/A			
Q	220 – 240	60	3	3	8	15	14	2.5	72	80	4	25.0
N	440 – 480	60	3	3	5	15	14	2.5	37	40	8	10.0
P	380 – 415	50	3	3	5	15	14	2.5	33	40	8	10.0
V-Speed Models												
X	220 – 240	60	1/3	2/3	15/9	20/15	12/14	4/2.5	N/A			
Q	220 – 240	60	3	3	9	15	14	2.5	72	80	4	25.0
N	440 – 480	60	3	3	6	15	14	2.5	37	40	8	10.0
P	380 – 415	50	3	3	6	15	14	2.5	33	40	8	10.0

NOTE: Wire sizes shown are for copper, THHN, 90°C conductor per NEC article 310.

Table 14

100 Pound Capacity Models												
Voltage Designation					Standard				Electric Heat			
Code	Voltage	Cycle	Phase	Wire	Full Load Amps	Circuit Breaker	AWG	mm ²	Full Load Amps	Circuit Breaker	AWG	mm ²
F-Speed Models												
X	220 – 240	60	1/3	2/3	16/9	20/15	12/14	4/2.5	N/A			
Q	220 – 240	60	3	3	9	15	14	2.5	74	80	4	25.0
N	440 – 480	60	3	3	6	15	14	2.5	37	40	8	10.0
P	380 – 415	50	3	3	6	15	14	2.5	34	40	8	10.0
V-Speed Models												
X	220 – 240	60	1/3	2/3	16/10	20/15	12/14	4/2.5	N/A			
Q	220 – 240	60	3	3	10	15	14	2.5	74	80	4	25.0
N	440 – 480	60	3	3	7	15	14	2.5	37	40	8	10.0
P	380 – 415	50	3	3	7	15	14	2.5	34	40	8	10.0

NOTE: Wire sizes shown are for copper, THHN, 90°C conductor per NEC article 310.

Table 15

Installation

125 Pound Capacity Models												
Voltage Designation					Standard				Electric Heat			
Code	Voltage	Cycle	Phase	Wire	Full Load Amps	Circuit Breaker	AWG	mm ²	Full Load Amps	Circuit Breaker	AWG	mm ²
N	440 – 480	60	3	3	10	15	14	2.5	N/A			
P	380 – 415	50	3	3	10	15	14	2.5	N/A			
Q	200 – 240	50/60	3	3	11	15	14	2.5	N/A			

NOTE: Wire sizes shown are for copper, THHN, 90°C conductor per NEC article 310.

Table 16

CE Models

20 Pound Capacity Models										
Voltage Designation					Standard			Electric Heat		
Code	Voltage	Cycle	Phase	Wire	Full Load Amps	Circuit Breaker	mm ²	Full Load Amps	Circuit Breaker	mm ²
F-Speed Models										
X	220 – 240	50	1/3	2/3	4/3	6	2.5	N/A		
Q	220 – 240	50	3	3	3	6	2.5	21	25	2.5
P	380 – 415	50	3	3	2	6	2.5	13	16	2.5
V-Speed Models										
X	220 – 240	50	2/3	1/3	4/3	6	2.5	N/A		
Q	220 – 240	50	3	3	3	6	2.5	21	25	2.5
P	380 – 415	50	3	3	2	6	2.5	13	16	2.5

NOTE: Wire sizes shown are for copper, THHN, 90°C conductor per NEC article 310.

Table 17

30 Pound Capacity Models										
Voltage Designation					Standard			Electric Heat		
Code	Voltage	Cycle	Phase	Wire	Full Load Amps	Circuit Breaker	mm ²	Full Load Amps	Circuit Breaker	mm ²
F-Speed Models										
X	220 – 240	50	1/3	2/3	5/4	6	2.5	N/A		
Q	220 – 240	50	3	3	4	6	2.5	22	25	2.5
P	380 – 415	50	3	3	3	6	2.5	13	16	2.5
V-Speed Models										
X	220 – 240	50	1/3	2/3	7/4	10/6	2.5	N/A		
Q	220 – 240	50	3	3	4	6	2.5	22	25	2.5
P	380 – 415	50	3	3	3	6	2.5	13	16	2.5

NOTE: Wire sizes shown are for copper, THHN, 90°C conductor per NEC article 310.

Table 18

Installation

40 Pound Capacity Models										
Voltage Designation					Standard			Electric Heat		
Code	Voltage	Cycle	Phase	Wire	Full Load Amps	Circuit Breaker	mm ²	Full Load Amps	Circuit Breaker	mm ²
F-Speed Models										
X	220 – 240	50	1/3	2/3	7/4	10/6	2.5	N/A		
Q	220 – 240	50	3	3	4	6	2.5	42	50	10.0
P	380 – 415	50	3	3	3	6	4.0	26	32	2.5
V-Speed Models										
X	220 – 240	50	1/3	2/3	7/4	10/6	2.5	N/A		
Q	220 – 240	50	3	3	4	6	2.5	42	50	10.0
P	380 – 415	50	3	3	3	6	2.5	26	32	2.5

NOTE: Wire sizes shown are for copper, THHN, 90°C conductor per NEC article 310.

Table 19

60 Pound Capacity Models										
Voltage Designation					Standard			Electric Heat		
Code	Voltage	Cycle	Phase	Wire	Full Load Amps	Circuit Breaker	mm ²	Full Load Amps	Circuit Breaker	mm ²
F-Speed Models										
X	220 – 240	50	1/3	2/3	11/7	16/10	2.5	N/A		
Q	220 – 240	50	3	3	7	10	2.5	43	50	10.0
P	380 – 415	50	3	3	4	6	4.0	26	32	2.5
V-Speed Models										
X	220 – 240	50	1/3	2/3	11/7	16/10	2.5	N/A		
Q	220 – 240	50	3	3	7	10	2.5	43	50	10.0
P	380 – 415	50	3	3	4	6	2.5	26	32	2.5

NOTE: Wire sizes shown are for copper, THHN, 90°C conductor per NEC article 310.

Table 20

80 Pound Capacity Models										
Voltage Designation					Standard			Electric Heat		
Code	Voltage	Cycle	Phase	Wire	Full Load Amps	Circuit Breaker	mm ²	Full Load Amps	Circuit Breaker	mm ²
F-Speed Models										
X	220 – 240	50	1/3	2/3	12/8	16/10	2.5	N/A		
Q	220 – 240	50	3	3	8	10	2.5	72	80	16.0
P	380 – 415	50	3	3	7	10	2.5	33	40	4.0
V-Speed Models										
X	220 – 240	50	1/3	2/3	17/11	20/16	2.5	N/A		
Q	220 – 240	50	3	3	11	16	2.5	72	80	16.0
P	380 – 415	50	3	3	7	10	2.5	33	40	4.0

NOTE: Wire sizes shown are for copper, THHN, 90°C conductor per NEC article 310.

Table 21

100 Pound Capacity Models										
Voltage Designation					Standard			Electric Heat		
Code	Voltage	Cycle	Phase	Wire	Full Load Amps	Circuit Breaker	mm ²	Full Load Amps	Circuit Breaker	mm ²
F-Speed Models										
X	220 – 240	50	1/3	2/3	17/11	20/16	2.5	N/A		
Q	220 – 240	50	3	3	11	16	2.5	74	80	25.0
P	380 – 415	50	3	3	7	10	2.5	34	40	4.0
V-Speed Models										
X	220 – 240	50	1/3	2/3	17/11	20/16	2.5	N/A		
Q	220 – 240	50	3	3	11	16	2.5	74	80	25.0
P	380 – 415	50	3	3	7	10	2.5	34	40	4.0

NOTE: Wire sizes shown are for copper, THHN, 90°C conductor per NEC article 310.

Table 22

Installation

125 Pound Capacity Models												
Voltage Designation					Standard				Electric Heat			
Code	Voltage	Cycle	Phase	Wire	Full Load Amps	Circuit Breaker	AWG	mm ²	Full Load Amps	Circuit Breaker	AWG	mm ²
N	440 – 480	60	3	3	10	15	14	2.5	N/A			
P	380 – 415	50	3	3	10	15	14	2.5	N/A			
Q	200 – 240	50/60	3	3	11	15	14	2.5	N/A			

NOTE: Wire sizes shown are for copper, THHN, 90°C conductor per NEC article 310.

Table 23

Steam Requirements (Steam Heat Option Only)

	WARNING
<p>Hot Surfaces. Will cause severe burns. Turn steam off and allow steam pipes, connections and components to cool before touching.</p>	
W505	

For machines equipped with optional steam heat, install piping in accordance with approved commercial steam practices. Steam requirements are shown in *Table 24*.

Steam Supply Information		
Steam inlet connection size	40 – 100 pound*	1/2 in. (13 mm)
	125 pound	3/4 in. (19 mm)
Number of steam inlets	1	
Recommended pressure	30 – 80 psi (2.0 – 5.4 bar)	
Maximum pressure	80 psi (5.4 bar)	

* 20 and 30 pound models can be prep for steam and a kit is available for conversion.

Table 24

IMPORTANT: Failure to install the customer supplied steam filter may void the warranty.

Supply Dispensing

	WARNING
<p>Dangerous Chemicals. May damage eyes and skin. Wear eye and hand protection when handling chemicals; always avoid direct contact with raw chemicals. Read the manufacturer's directions for accidental contact before handling chemicals. Ensure an eye-rinse facility and an emergency shower are within easy reach. Check at regular intervals for chemical leaks.</p>	
W363	

Supply Dispensing		
Capacities	20 – 100	125
Number of supply compartments	4	0 or 5 (optional)
Number of external liquid supply connections (OPL only)	5	5
Liquid supply connection size	3/8 in. (8 mm)	5/8 in. (15.9 mm)

Table 25

IMPORTANT: Undiluted chemical dripping can damage the machine. All chemical injection supply dispenser pumps and dispenser tubing should be mounted below the washer's injection point. Loops do not prevent drips if these instructions are not followed.

IMPORTANT: Failure to follow these instructions could damage the machine and void the warranty.

Installation

External Supplies

For proper communication between the machine and an external chemical supply system, it is important for the low-voltage signal power to be connected properly. The included wiring diagram shows several different options for safe and correct wiring of this interface.

The preferred method for connecting the wiring from the external chemical supply system to the machine is to use the 300mA power of the machine's 24VAC control transformer, which is intended strictly for this purpose. Other voltage and current options are available, but require some wiring changes and must be provided with an external power source. Under no circumstances should the high-voltage machine supply connections or source be used for the communication wiring.

Communication wiring connections, which include a single row of identified terminal blocks, can be found under a service panel at the upper back of the machine.

Chemical Injection Using Internal 24VAC Control Transformer

NOTE: Using the Internal 24VAC 300 Milliamp Control Transformer is recommended by Alliance Laundry Systems.

	CAUTION
<p>Do not attempt to increase fuse rating or alter wiring of external chemical supply terminal strip in such a way that may conflict with the suggested methods provided on the Optional External Supply Wiring Diagram.</p>	
<small>W699</small>	

IMPORTANT: DO NOT remove the red jumper wire from the terminal strip. Refer to *Figure 46*.

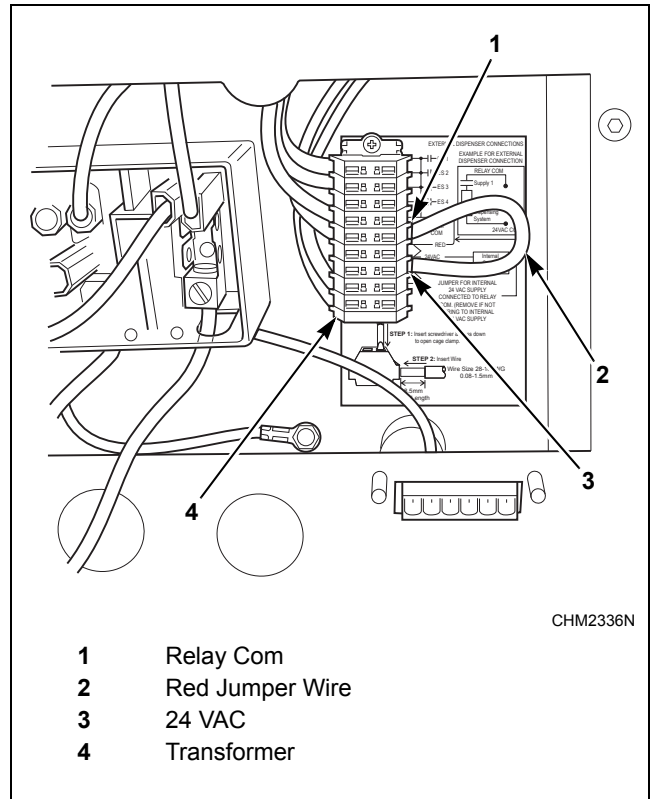
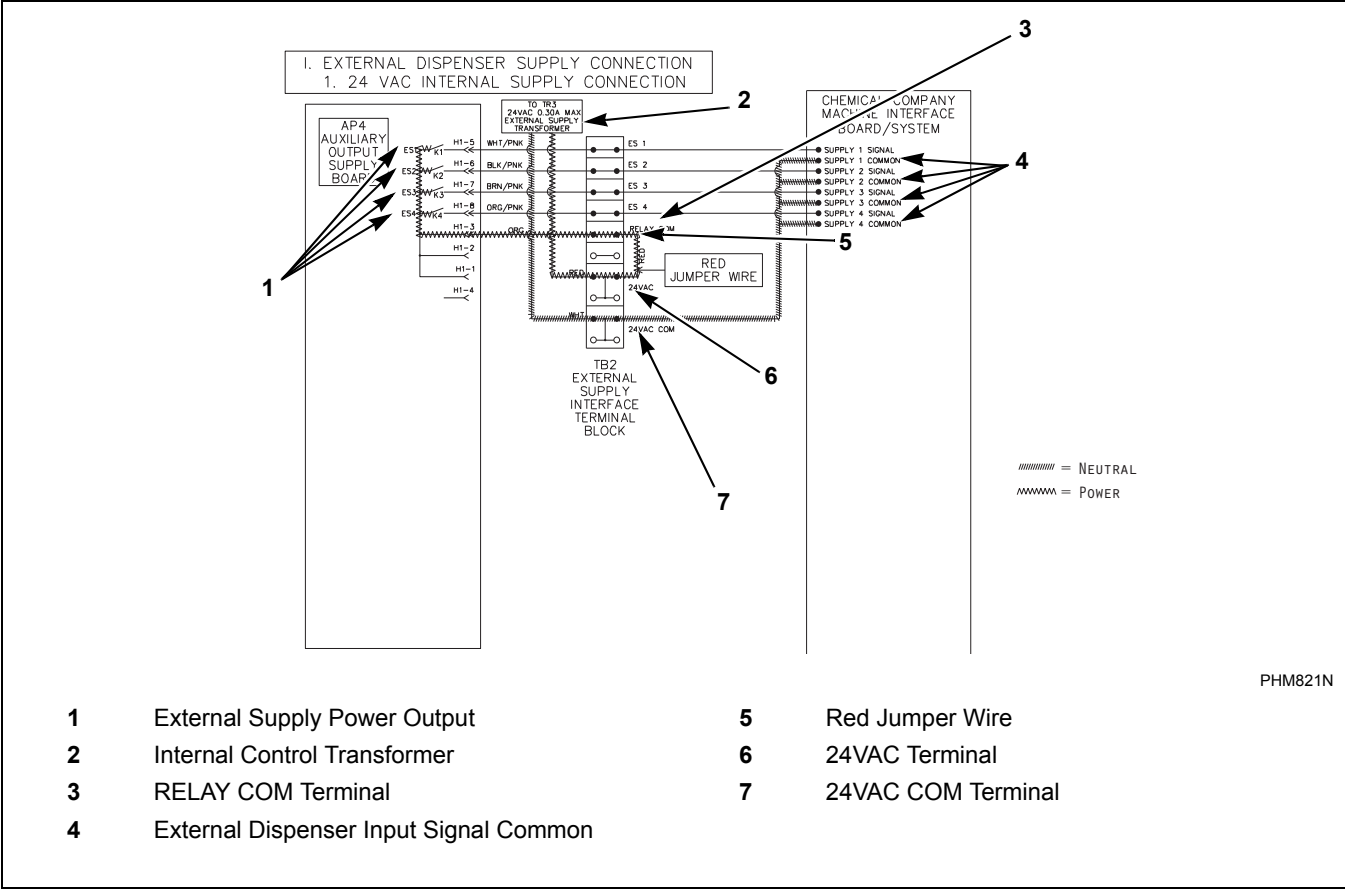

Figure 46

There are 3 terminals necessary for this connection option.

- Terminal “24VAC COM” is used to connect one side of the internal control transformer to the external dispenser input signals common.
- The second terminal is used to connect the other side of the control transformer to the machine output signals common through a red jumper wire between “24VAC” and “RELAY COM”. Refer to *Figure 47*.

IMPORTANT: Do not use the transformer terminals if an external power supply is used.



PHM821N

Figure 47

Installation

Chemical injection Using External AC Power Source

NOTE: An External AC Power Source is **NOT** provided by Alliance Laundry Systems.

NOTE: Power for external supplies must not be derived from the high-voltage main power connection point.

IMPORTANT: The external power must supply power of 240VAC or less and be protected at 3 Amps or less.

1. Remove the red jumper wire installed by the factory between “24VAC”, and “RELAY COM”.
2. Connect one side of the external power to the “RELAY COM” and the other to the external dispenser input signals common. Refer to *Figure 48*.

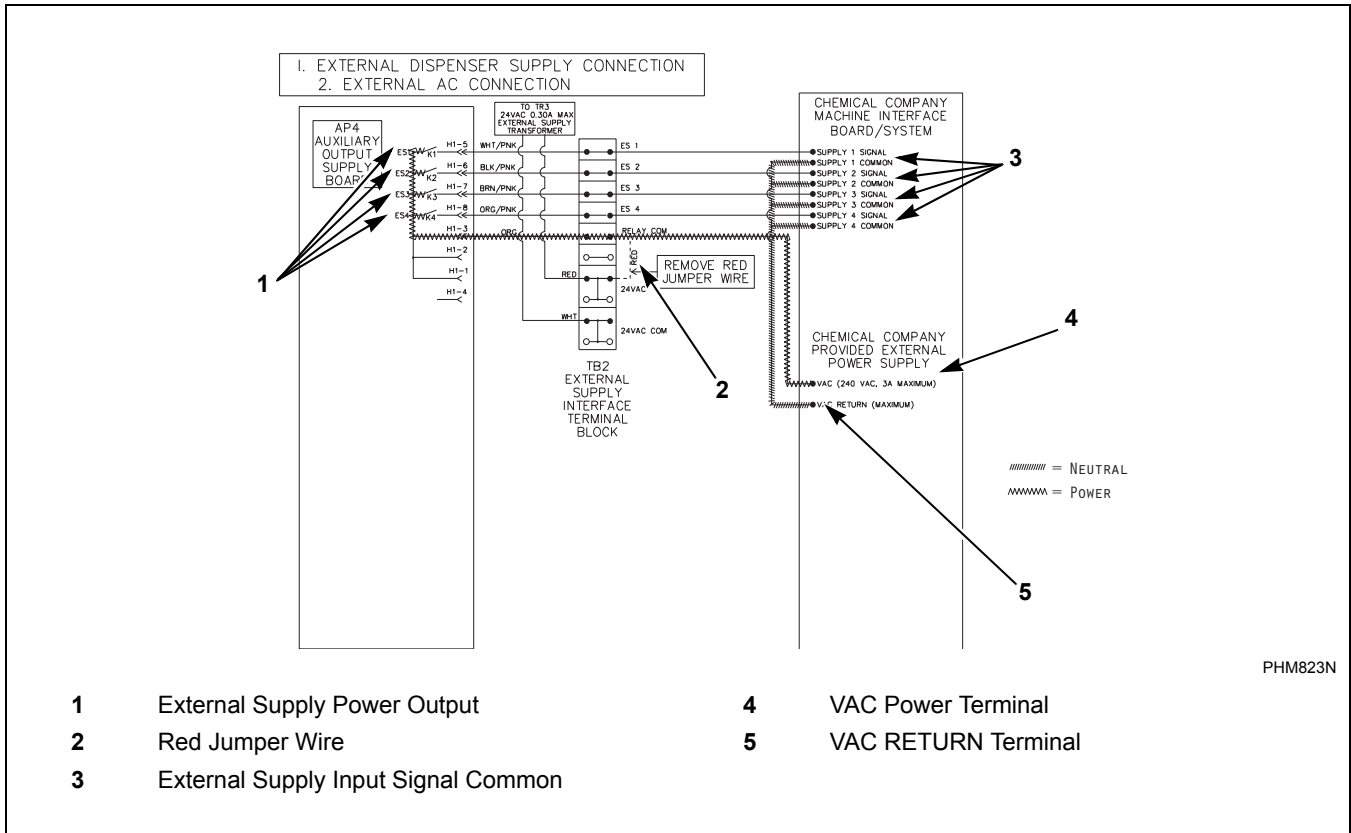

PHM823N

Figure 48

CAUTION

Do not attempt to increase fuse rating or alter wiring of external chemical supply terminal strip in such a way that may conflict with the suggested methods provided on the Optional External Supply Wiring Diagram.

W699

External Supply Signals

Wash-cycle signals are provided to the external chemical supply equipment and a “wait for the next step” signal can be received from the supply equipment.

For example, if ES1 is selected the K1 contact will close and power will be supplied to Supply 1 Signal. The contact will remain closed for the amount of time programmed in control. Refer to *Figure 49* for Internal Supply Connection or *Figure 50* for External AC Connection.

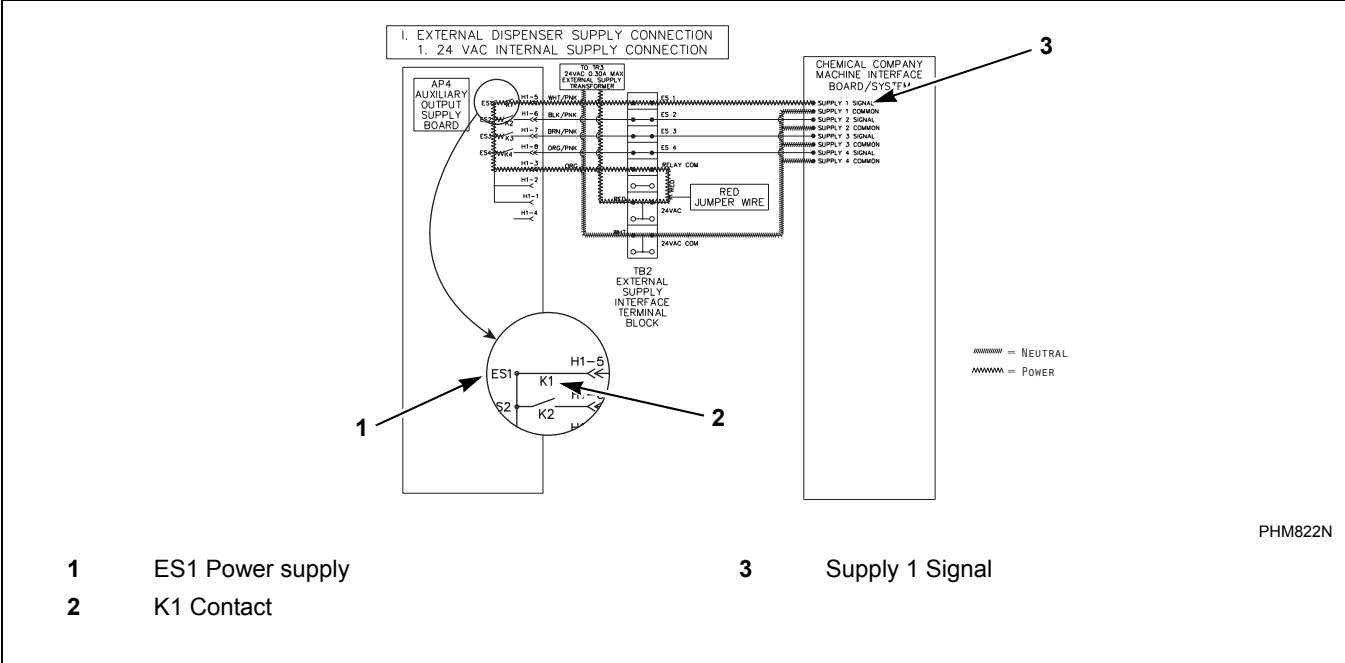

Figure 49

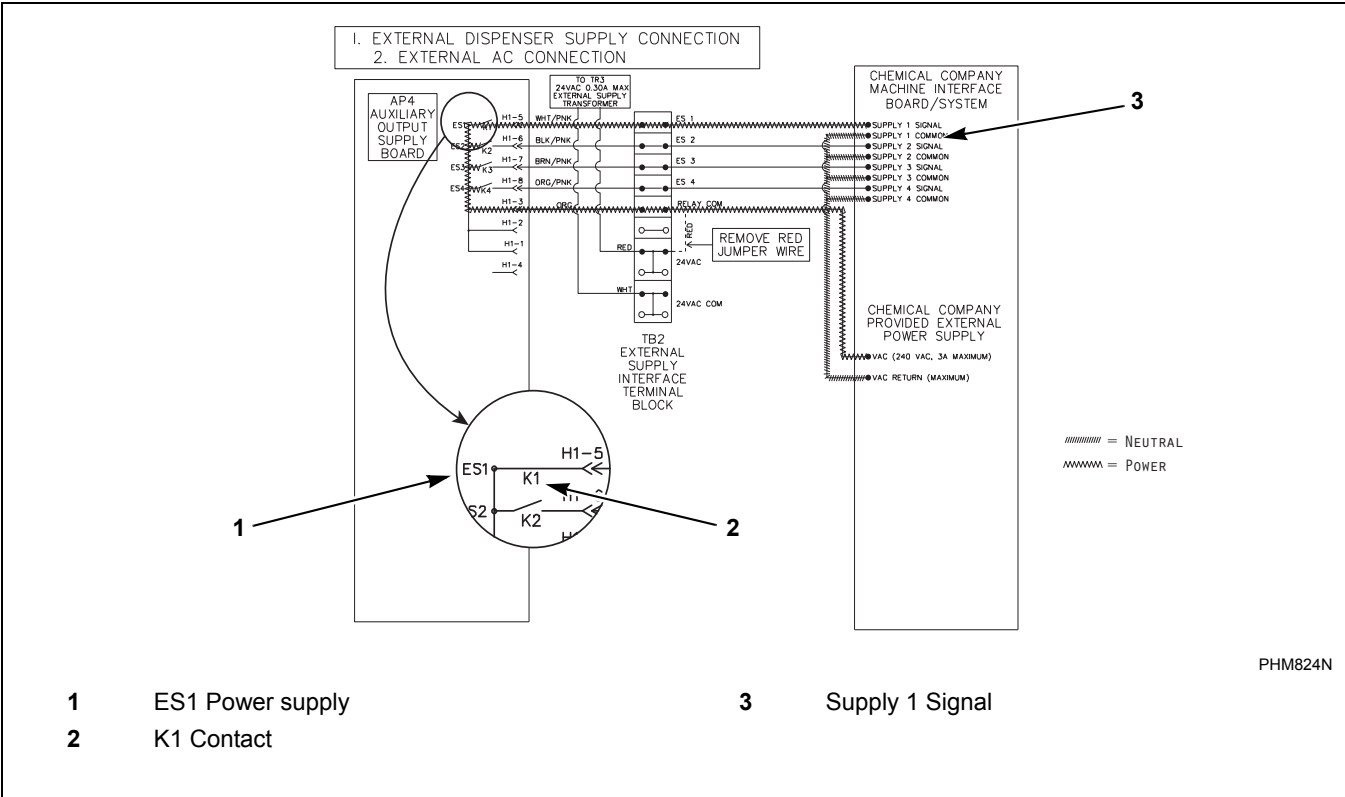

Figure 50

Installation

Connection of External Liquid Supplies

20 – 100 Pound OPL Models

1. Facing the rear of the machine, locate the five 3/8 inch supply hose connections found on the right-hand side of the valve panel. Refer to *Figure 51*.

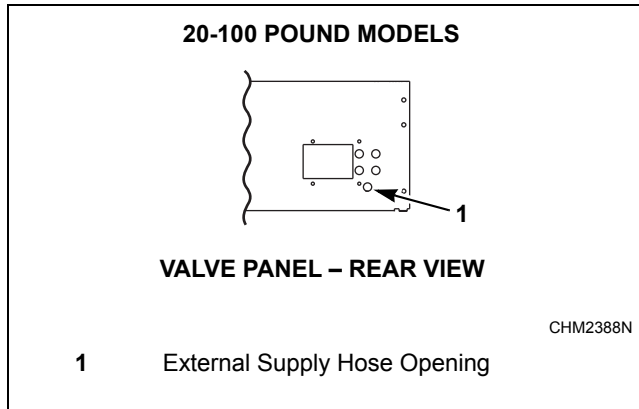

Figure 51

2. Drill through the five plastic holes on the valve panel for the external supply hoses as needed.
3. Remove plastic debris.
4. Attach the external supply hoses to the ports at each of the drilled holes.
5. Secure with proper clamps.

NOTE: Do not attempt to make chemical injection supply pump electrical connections to points other than those provided specifically for that purpose by the factory.

125 Pound OPL Models (With Optional Dispenser)

Refer to *Figure 52*.

1. Remove plugs from base. Plugs are assembled inside tubing ring.
2. Install strain reliefs with the seal nuts.
3. Insert tubes through base. Do not remove dry supply cups. Tube should extend into plastic cup, with exception of softener tube, which should be routed to outside of cup.
4. Tighten seal nut to prevent tubing from escaping assembly.

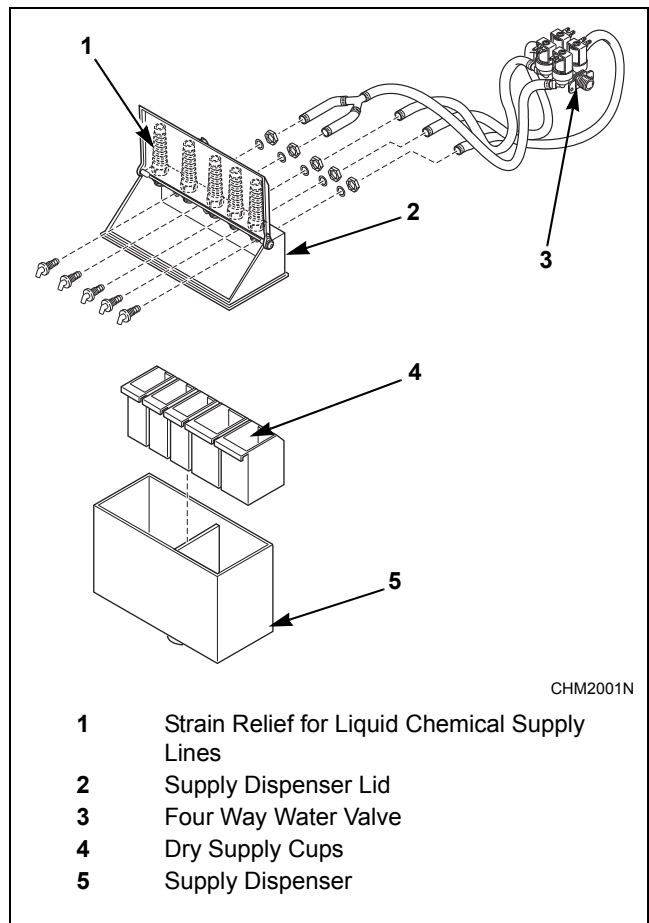

Figure 52

Start Up

Pallet Jack cover Plate Installation (80 and 100 Pound Models Only)

After machine is fully installed, the optional pallet jack cover plate can be installed.

1. Locate the two holes on the front of the machine base frame. Refer to *Figure 53*.

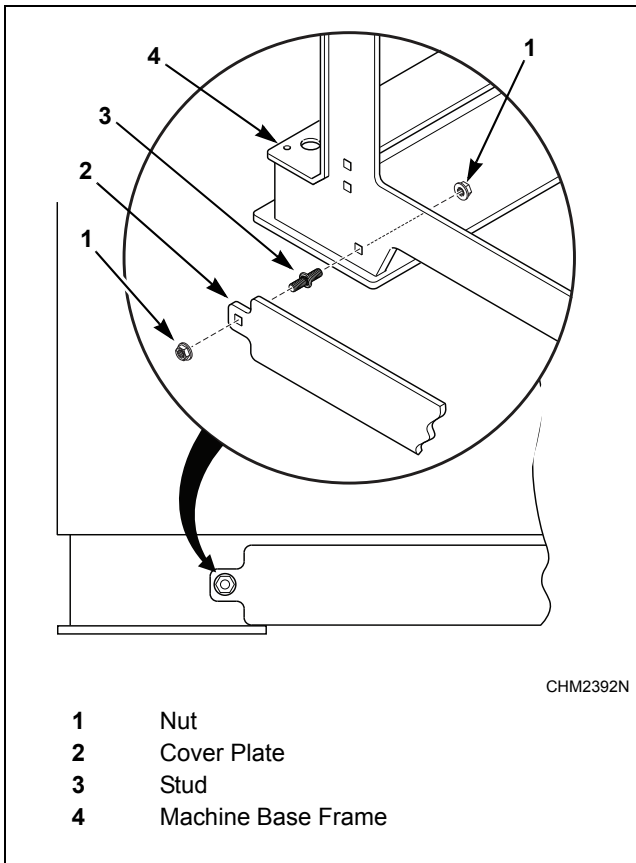

Figure 53

2. Using the hardware from removing plate from back panel, install the cover plate to the machine base frame. The square on stud goes into square hole in machine frame. Refer to *Figure 53*.

Basket Rotation

Check that basket rotation is counterclockwise in the extract step.

1. If rotation is not counterclockwise, disconnect power to machine.
2. Have a qualified electrician reverse any two motor leads at the AC terminal block.

Operation

Operating Instructions

1. Turn on main power source (circuit breaker).
2. Turn handle clockwise to open. Refer to *Figure 54*.

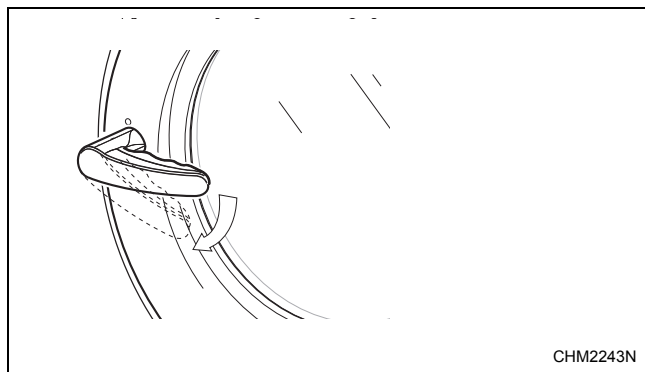

Figure 54

3. Load to capacity whenever possible. DO NOT OVERLOAD. Refer to *Figure 55*.

NOTE: Underloading can cause out-of-balance conditions that can shorten machine life.

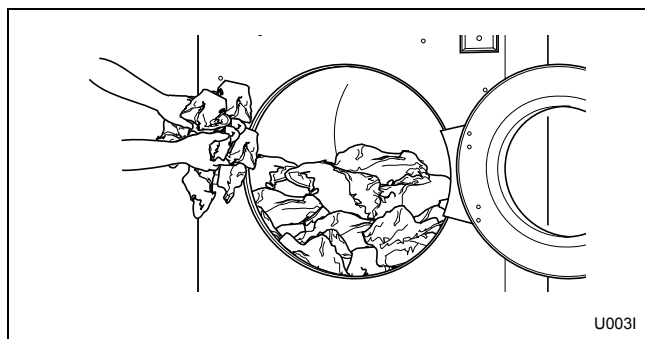

Figure 55

4. Close door and turn handle counter clockwise. Refer to *Figure 56*.

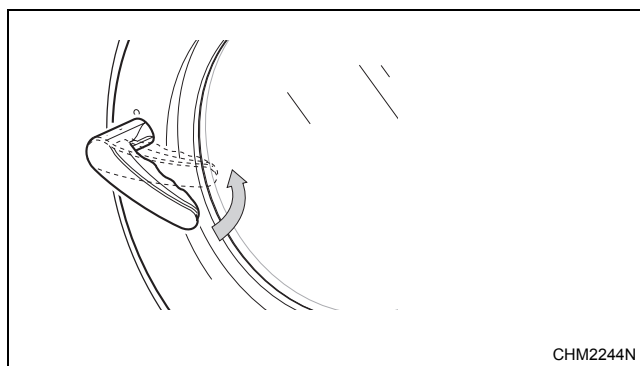

Figure 56

5. The default wash cycle will display.



WARNING

To prevent personal injury, avoid contact with inlet water temperatures higher than 125° Fahrenheit (51° Celsius) and hot surfaces.

W748

6. Select the desired soil setting (select models only), cycle setting (select models only) and cycle/temperature. The LED indicator(s) for that cycle will light.

7. Add liquid and/or powder supplies to supply dispenser. Refer to *Figure 57*.

a. Detergent:

- Liquid - Compartment 1 (prewash) + Compartment 3
- Powder - Compartment 1 (prewash) + Compartment 2

b. Bleach:

- Liquid - Compartment 3
- Powder - Compartment 2

c. Softener:

- Liquid - Compartment 4

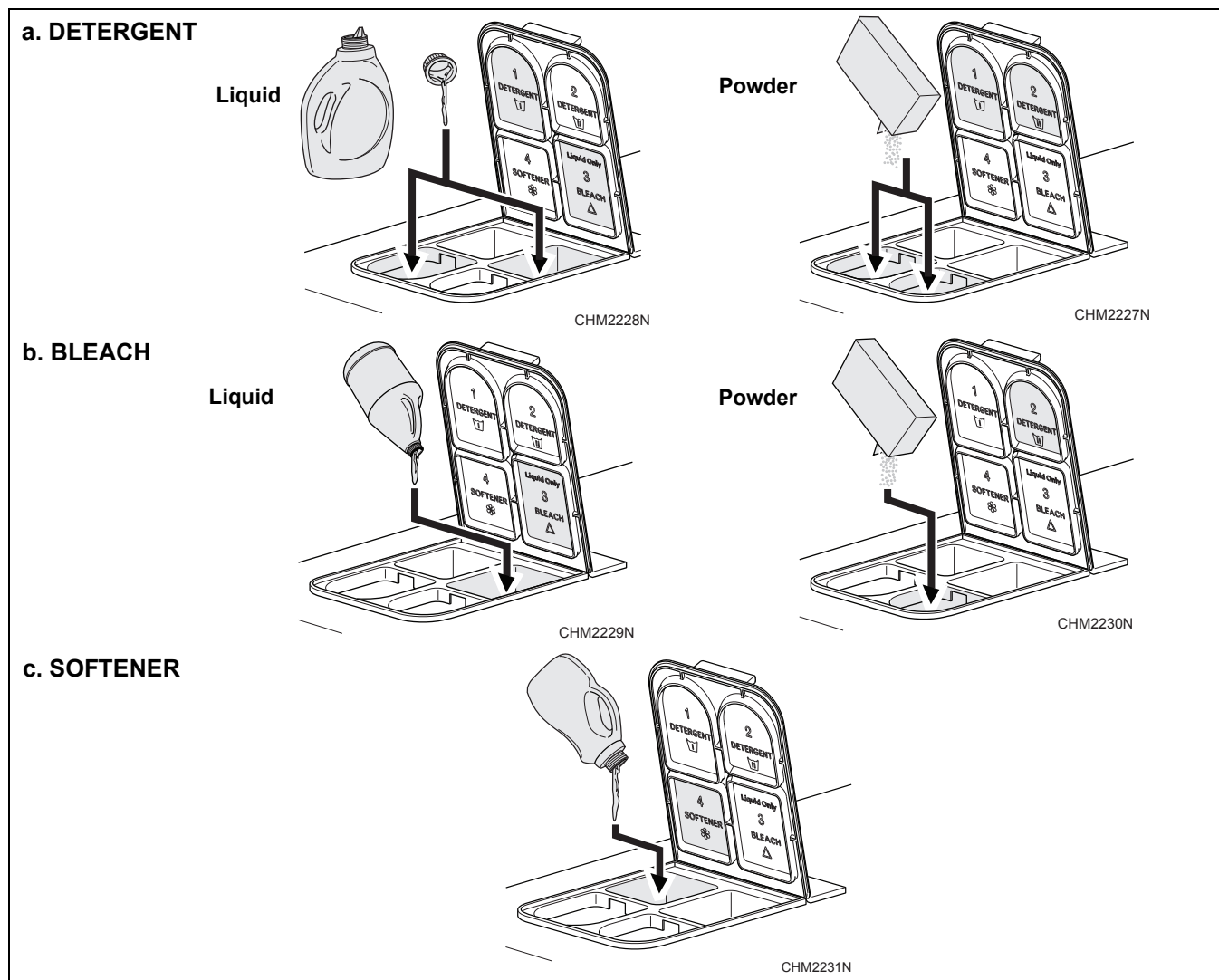



Figure 57

8. **For vended models only**, insert coin(s) or card as necessary.
- If the machine is a coin operated unit, add coins. As each coin is added, the vend counts down to the amount remaining.
 - If the machine is a card operated unit, insert and remove card per card system instructions.
 - If the unit is interfaced to a central/remote pay system, go to the central/remote pay console,

make payment and select the machine and follow central/remote pay system instructions.

9. Press the START keypad.
10. During first fill, the desired wash cycle can be changed. After first fill has ended, the wash cycle active at that moment remains the chosen wash cycle.
11. When cycle is complete, display shows “00”.

Maintenance

	WARNING
Sharp edges can cause personal injury. Wear safety glasses and gloves, use proper tools and provide lighting when handling sheet metal parts.	
<small>W366R1</small>	

IMPORTANT: Replace all panels that are removed to perform service and maintenance procedures. Do not operate the machine with missing guards or with broken or missing parts. Do not bypass any safety devices.

Daily

	WARNING
Do not spray the machine with water. Short circuiting and serious damage may result.	
<small>W782</small>	

IMPORTANT: Door lock should be checked daily to ensure proper operation. Also check that all safety and instruction stickers are on the machine. Any missing or illegible safety instructions stickers should be replaced immediately.

Beginning of Day

1. Check door interlock before starting operation:
 - a. Attempt to start the machine with the door open. The machine should not start.
 - b. Close the door without locking it and start the machine. The machine should not start.
 - c. Attempt to open the door while the cycle is in progress. The door should not open.

If the door lock and interlock are not functioning properly, disconnect power and call a service technician.

2. Inspect water inlet valve hose connections on the back of the machine for leaks.
3. Inspect steam hose connections for leaks (where applicable).
4. Inspect all chemical inlets, lines and connections for leaks.

End of Day

1. Clean the door gasket of residual detergent and all foreign matter.
2. Clean the door glass with a damp cloth.
3. Clean automatic supply dispenser lid and general area.
4. Clean the machine's top, front and side panels with mild detergent. Rinse with clean water. DO NOT use products that contain alcohol on the control panel.
5. Inspect and clean basket.

NOTE: Unload the machine promptly *after each completed cycle* to prevent moisture buildup. Leave loading door open *after each completed cycle* to allow moisture to evaporate.

Weekly

1. Check the machine for leaks.
 - a. Start an unloaded cycle to fill the machine.
 - b. Verify that door and door gasket do not leak.
 - c. Verify that the drain valve is operating and that the drain system is free from obstruction. If water does not leak out during the first wash segment, the drain valve is closed and functioning properly.
2. Clean the AC drive box filter(s) weekly or more frequently as needed (where applicable):

IMPORTANT: The control module cover and fan filter must be in place for the fan to properly cool the AC inverter drive. Failure to observe this warning will void the warranty and could lead to expensive AC inverter drive repair.

Monthly

NOTE: Disconnect power to the machine at its source before performing the monthly maintenance procedures.

1. Check belt(s) require replacement or adjustment. Call a qualified service technician in either case.
 - a. Check belt(s) for uneven wear and frayed edges.
 - b. For groove-pulley drive systems, verify alignment by placing a straightedge across both pulley faces. The straightedge should make contact with the pulleys in four places. Refer to *Figure 58*.

- c. For flat-pulley drive systems, verify allowable distance of belt from edge of basket pulley. Refer to *Table 26*.

Flat-Pulley Alignment	
Model	Minimum Allowable Distance from Edge
20	.09 in. (2 mm)
30	.09 in. (2 mm)
40	.09 in. (2 mm)
60	.38 in. (10 mm)

Table 26

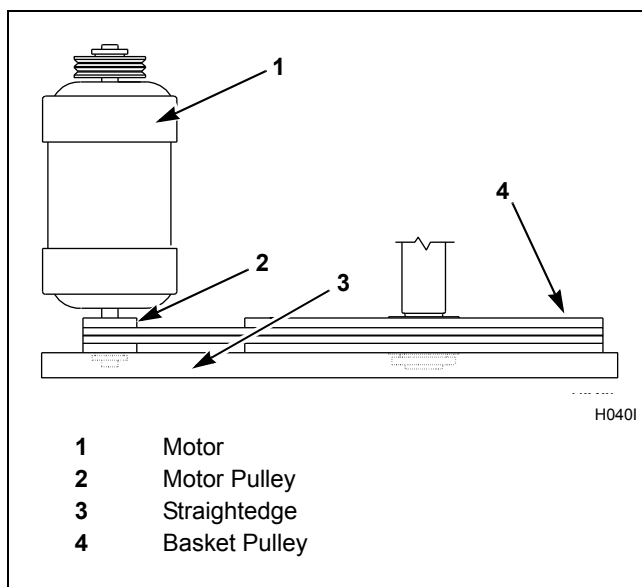

Figure 58

Belt Tension by Frequency or Belt Tension Gauge			
Model*	Frequency (Hz)	Belt Tension (lbs.)	Tension Gauge
20 (1 HP)	109 ± 2	50 ± 2	224 ± 8
80	102 ± 4	132 ± 10	588 ± 45
100	119 ± 4	145 ± 5	647 ± 22

* 20 pound 2 HP High Voltage and all 30, 40 and 60 pound Models are self-tensioning and do not require any adjustment.

Table 27

Maintenance

2. **For 80 through 125 pound capacity models only**, lubricate bearings and seals each month OR after every 200 hours of operation.
 - a. Use a premium-grade lithium-based #2 grease. Never mix two types of grease, such as petroleum and silicone.
 - b. Pump the grease gun slowly, permitting only the following number of strokes:
 - Bearing grease fittings, 2 strokes each
 - Seal grease fitting, 2 stroke (125 pound models only)

NOTE: Do not pump the grease gun until grease comes out of the bearing housing. This can result in over lubrication, causing damage to bearings and seals.

3. Check overflow hose and drain hose for leaks.
4. Check the supply dispenser hoses and hose connections.
5. Clean inlet hose filter screens:
 - a. Turn water off and allow valve to cool, if necessary.
 - b. Unscrew inlet hose and remove filter screen.
 - c. Clean with soapy water and reinstall. Replace if worn or damaged.

Quarterly

NOTE: Disconnect power to the machine at its source before performing the quarterly maintenance procedures.

1. Tighten door hinges and fasteners, if necessary.
2. Tighten anchor bolts, if necessary.
3. Verify that the drain motor shield is in place and secure, if so equipped.
4. Clean customer-supplied steam filter, where applicable. Refer to *Figure 59*.
 - a. Turn off steam supply and allow time for the valve to cool.
 - b. Unscrew cap.
 - c. Remove element and clean.
 - d. Replace element and cap.

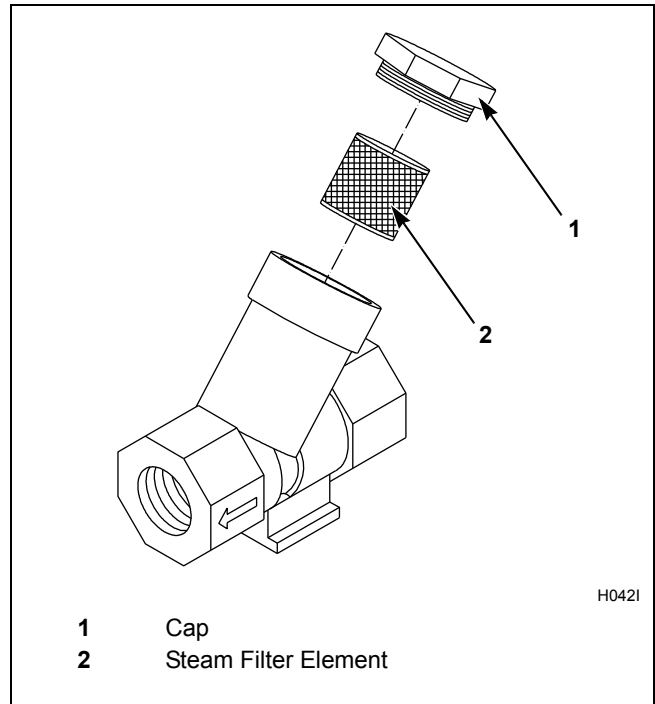

Figure 59

5. Check the bearing mounting bolts to make sure they are torqued properly. Refer to *Table 28*.

Machine Capacity	Bearing	Torque
20	All	41 ft.-lbs.
30-40	All	101 ft.-lbs.
60	All	201 ft.-lbs.
80-100	All	357 ft.-lbs.
125	All	201 ft.-lbs.

Table 28

6. Tighten motor mounting bolt locknuts and bearing bolt locknuts.
7. Vacuum lint from motor vents.
8. Clean all electronic boards of moisture and dust with canned air.
9. Verify the insulation is intact on all external wires and that all connections are secure. If bare wire is evident, call a service technician.
10. Clean AC drive cooling fan blades (where applicable).

Care of Stainless Steel

- Remove dirt and grease with detergent and water. Thoroughly rinse and dry after washing.
- Avoid contact with dissimilar metals to prevent galvanic corrosion when salty or acidic solutions are present.
- Do not allow salty or acidic solutions to evaporate and dry on stainless steel. Wipe clean of any residues.
- Rub in the direction of the polish lines or “grain” of the stainless steel to avoid scratch marks when using abrasive cleaners. Use stainless steel wool or soft, non-metal bristle brushes. Do not use ordinary steel wool or steel brushes.
- If the stainless steel appears to be rusting, the source of the rust may be an iron or steel part not made of stainless steel, such as a nail or screw.
- Remove discoloration or heat tint from overheating by scouring with a powder or by employing special chemical solutions.
- Do not leave sterilizing solutions on stainless steel equipment for prolonged periods of time.
- When an external chemical supply is used, ensure no siphoning of chemicals occurs when the machine is not in use. Highly concentrated chemicals can cause severe damage to stainless steel and other components within the machine. Damage of this kind is not covered by the manufacturer’s warranty. Locate the pump and tubing below the machines’s injection point to prevent siphoning of chemicals into the machine.

Disposal of Unit

This appliance is marked according to the European directive 2002/96/EC on Waste Electrical and Electronic Equipment (WEEE).

This symbol on the product or on its packaging indicates that this product shall not be treated as household waste. Refer to *Figure 60*. Instead it shall be handed over to the applicable collection point for the recycling of electrical and electronic equipment. Ensuring this product is disposed of correctly will help prevent potential negative consequences for the environment and human health which could otherwise be caused by inappropriate waste handling of this product. The recycling of materials will help to conserve natural resources. For more detailed information about recycling of this product, please contact the local city office, household waste disposal service, or the source from which the product was purchased.

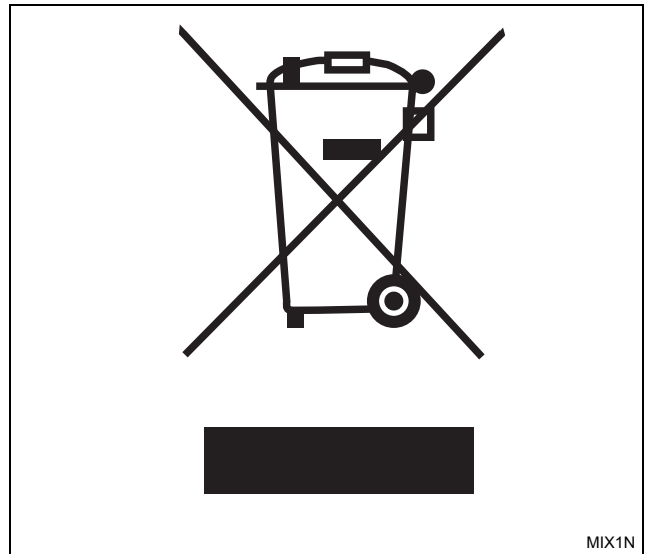

Figure 60