

# Washer Extractors

**HF455, HF575, HF730, HF900**

**for corresponding “CHF”, “CS”, “IS”  
and “IHF” models, see page 5 for complete  
model list**

**Technical specifications  
Installation instructions  
Maintenance**



# Contents

---

<b>1 Model Numbers</b>	<b>5</b>
<b>2 Safety and Environmental Informations</b>	<b>6</b>
Safety	6
Environmental	7
Explanation of Safety Messages	8
Important Safety Instructions	9
Operator Safety	11
<b>3 Technical data and dimensions</b>	<b>12</b>
Technical data HF455, IHF455, IHF100, IS100, CHF100, CS100	12
Dimensions HF455, IHF455, IHF100, IS100, CHF100, CS100	13
Technical data HF575, IHF575, IHF135, IS135, CHF135, CS135	14
Dimensions HF575, IHF575, IHF135, IS135, CHF135, CS135	15
Technical data HF730, IHF730, IHF165, IS165, CHF165, CS165	16
Dimensions HF730, IHF730, IHF165, IS165, CHF165, CS165	17
Technical data HF900, IHF900	18
Dimensions HF900, IHF900	19
<b>4 Installation and Connection Instructions</b>	<b>20</b>
Surface	20
Removal of the transport safety	20
Mounting Bolt Hole Locations for machines, HF455, IHF455, IHF100, IS100, CHF100, CS100	21
Mounting Bolt Hole Locations for machines, HF575, IHF575, IHF135, IS135, CHF135, CS135	22
Mounting Bolt Hole Locations for machines, HF730, IHF730, IHF165, IS165, CHF165, CS165	23
Mounting Bolt Hole Locations for machines, HF900, IHF900	24
Water connection	25
Water drain	25
Electrical Installation	26
Main power connection	28
Electrical Specifications HF455, IHF455, IHF100, IS100, CHF100, CS100	30
Electrical Specifications HF575, IHF575, IHF135, IS135, CHF135, CS135	31
Electrical Specifications HF730, IHF730, IHF165, IS165, CHF165, CS165	32
Electrical Specifications HF900, IHF900	33
Automatic lubricator	34
Liquid soap connection (option)	35
Connection of a central operating panel for coin machines (option)	37

**5 Steam connection ..... 38**

**6 Technical remarks ..... 39**

*Internal connections of the electrical heating ..... 39*

*Out of balance switch ..... 40*

*Opening the door in case of an emergency ..... 40*

**7 Maintenance instruction of the machine ..... 41**

*End of day ..... 41*

*General maintenance ..... 41*

*Periodical maintenance ..... 41*

*Annual maintenance ..... 42*

**8 Contact Information ..... 43**

*Nameplate ..... 43*

**9 Repair and after-sales service ..... 45**

**Model Numbers**

Build-up

xHF455
xHF575
xHF730
xHF900
xHF100yyHyyyyyy
xHF135yyHyyyyyy
xHF165yyHyyyyyy
xHF455yyHyyyyyy
xHF575yyHyyyyyy
xHF730yyHyyyyyy
xHF900yyHyyyyyy

Model numbers

IHF100ANH
IHF100MNH
IS100
IHF135ANH
IHF135MNH
IS135
IHF165ANH
IHF165MNH
IS165
IHF455ANH
IHF455MNH
IHF455ZNH
IHF575ANH
IHF575MNH
IHF575ZNH
IHF730ANH
IHF730MNH
IHF730ZNH
IHF900ANH
IHF900MNH
IHF900ZNH

CHF100ANH
CHF100MNH
CS100
CHF135ANH
CHF135MNH
CS135
CHF165ANH
CHF165MNH
CS165
CHF455ANH
CHF455MNH
CHF575ANH
CHF575MNH
CHF730ANH
CHF730MNH
CHF900ANH
CHF900MNH

**Safety**

**CAUTION LABELS**

Please familiarize yourself with the following standard warning symbols. They are used throughout this manual and on the equipment to alert you to possible hazards. Anyone operating or servicing this equipment must understand these symbols and must follow all safety rules in this manual.



**ELECTRICAL HAZARD**

This symbol alerts you to the presence of a dangerous voltage, which could cause a serious shock resulting in personal injury or death.



**CONSULT MANUAL**

This symbol warns you to consult the manual for important instructions concerning the machine and possible hazards.



**MOVING PARTS HAZARD**

This symbol alerts you to the presence of possible dangerous moving parts within the machine. Guards should always be in place when the machine is in operation. Be very careful when servicing the drive system.



**PINCHING HAZARD**

This warning symbol indicates the presence of a pinch point on the machine. This is a place where your hand might be pinched or crushed, resulting in a severe injury. Make sure you understand these hazards and keep all body parts clear of them.



**HOT SURFACE HAZARD**

This symbol indicates the presence of a potentially hot surface. Some machine surfaces and parts may become extremely hot during normal operation and should not be touched.



**ATTENTION**

This symbol identifies information about practices or circumstances that can lead to personal injury or death, property damage, or economic loss.

**Environmental**

**Disposal of Unit**



This appliance is marked according to the European directive 2002/96/EC on Waste Electrical and Electronic Equipment (WEEE).

This symbol on the product or on its packaging indicates that this product shall not be treated as household waste. Instead it shall be handed over to the applicable collection point for the recycling of electrical and electronic equipment. Ensuring this product is disposed of correctly, you will help prevent potential negative consequences for the environment and human health, which could otherwise be caused by inappropriate waste handling of this product. The recycling of materials will help to conserve natural resources. For more detailed information about recycling of this product, please contact your local distributor resources.



**Explanation of Safety Messages**

Throughout this manual and on machine decals, you will find precautionary statements (“DANGER,” “WARNING,” and “CAUTION”) followed by specific instructions. These precautions are intended for the personal safety of the operator, user, servicer, and those maintaining the machine.

	<b>DANGER</b>
Indicates an imminently hazardous situation that, if not avoided, will cause severe personal injury or death.	
	<b>WARNING</b>
Indicates a hazardous situation that, if not avoided, could cause severe personal injury or death.	
	<b>CAUTION</b>
Indicates a hazardous situation that, if not avoided, may cause minor or moderate personal injury or property damage.	

**Safety Decals**

Safety decals appear at crucial locations on the machine. Failure to maintain legible safety decals could result in injury to the operator or service technician.

To provide personal safety and keep the machine in proper working order, follow all maintenance and safety procedures presented in this manual. If questions regarding safety arise, contact the manufacturer immediately.

Use manufacturer-authorized spare parts to avoid safety hazards.

Additional precautionary statements (“IMPORTANT” and “NOTE”) are followed by specific instructions.

**IMPORTANT:** The word “IMPORTANT” is used to inform the reader of specific procedures where minor machine damage will occur if the procedure is not followed.

**NOTE:** The word “NOTE” is used to communicate installation, operation, maintenance or servicing information that is important but not hazard related.

**Important Safety Instructions**

	<b>WARNING</b>
To reduce the risk of fire, electric shock, serious injury or death to persons when using your washer, follow these basic precautions:	

1. Read all instructions before using the washer.
2. Refer to the GROUNDING INSTRUCTIONS in the installation Manual for the proper grounding of the washer.
3. Do not wash textiles that have been previously cleaned, washed, soaked, or spotted with gasoline, dry-cleaning solvents, or other flammable or explosive substances as they give off vapors that could ignite or explode.
4. Do not add gasoline, dry-cleaning solvents, or other flammable or explosive substances to the wash water. These substances give off vapors that could ignite or explode.
5. Under certain conditions, hydrogen gas may be produced in a hot water system that has not been used for two weeks or more. HYDROGEN GAS IS EXPLOSIVE. If the hot water system has not been used for such a period, before using a washing machine or combination washer-dryer, turn on all hot water faucets and let the water flow from each for several minutes. This will release any accumulated hydrogen gas. The gas is flammable, do not smoke or use an open flame during this time.
6. Do not allow children to play on or in the washer. This appliance is not intended for use by young children or infirm persons without supervision. Young children should be supervised to ensure that they do not play with the appliance.
7. Before the washer is removed from service or discarded, remove the door to the washing compartment.
8. Do not reach into the washer if the wash drum is moving. This is an imminently hazardous situation that, if not avoided, will cause severe personal injury or death.
9. Do not install or store the washer where it will be exposed to water and/or weather.
10. Do not tamper with the controls.
11. Do not repair or replace any part of the washer, or attempt any servicing unless specifically recommended in the user-maintenance instructions or in published user-repair instructions that the user understands and has the skills to carry out.
12. To reduce the risk of an electric shock or fire, DO NOT use an extension cord or an adapter to connect the washer to an electrical power source.
13. Use a washer only for its intended purpose, washing textiles.
14. ALWAYS disconnect the washer from the electrical supply before attempting any service. Disconnect the power cord by grasping the plug, not the cord.
15. Install the washer according to the INSTALLATION INSTRUCTIONS. All connections for water, drain, electrical power and grounding must comply with local codes and be made by licensed personnel when required.
16. To reduce the risk of fire, textiles which have traces of any flammable substances such as vegetable oil, cooking oil, machine oil, flammable chemicals, thinner, etc., or anything containing wax or chemicals such as in mops and cleaning cloths, must not be put into the washer. These flammable substances may cause the fabric to catch on fire.
17. Do not use fabric softeners or products to eliminate static unless recommended by the manufacturer of the fabric softener or product.
18. Keep washer in good condition. Bumping or dropping the washer can damage safety features. If this occurs, have washer checked by a qualified service person.
19. Replace worn power cords and/or loose plugs.
20. Be sure water connections have a shut-off valve and that fill hose connections are tight. CLOSE the shut-off valves at the end of each wash day.

21. Loading door **MUST BE CLOSED** any time the washer is to fill, tumble, or spin. **DO NOT** bypass the loading door switch by permitting the washer to operate with the loading door open.
22. Always read and follow manufacturer's instructions on packages of laundry and cleaning aids. Heed all warnings or precautions. To reduce the risk of poisoning or chemical burns, keep them out of the reach of children at all times (preferably in a locked cabinet).
23. Always follow the fabric care instructions supplied by the textile manufacturer.
24. Never operate the washer with any guards and/or panels removed.
25. **DO NOT** operate the washer with missing or broken parts.
26. **DO NOT** bypass any safety devices.
27. Failure to install, maintain, and/or operate this washer according to the manufacturer's instructions may result in conditions which can produce bodily injury and/or property damage.
28. It is recommended that the machine be installed by qualified technicians.
29. Before starting repairs or maintenance, shut off all power and water supplies.
30. To prevent fire and explosion:  
Keep the area around the machine free from inflammable or combustible products.

**NOTE: The WARNINGS and IMPORTANT SAFETY INSTRUCTIONS appearing in this manual are not meant to cover all possible conditions and situations that may occur. Common sense, caution, and care must be exercised when installing, maintaining, or operating the washer.**

Any problems or conditions not understood should be reported to the dealer, distributor, service agent, or the manufacturer.

**SAVE THESE INSTRUCTIONS**

**Operator Safety**

	<b>WARNING</b>
<b>NEVER insert hands or objects into basket until it has completely stopped. Doing so could result in serious injury.</b>	

To ensure the safety of machine operators, the following maintenance checks must be performed daily:

1. Prior to operating the machine, verify that all warning signs are present and legible. Missing or illegible signs must be replaced immediately. Make certain that spares are available.
2. Check door interlock before starting operation of the machine:
  - a. Attempt to start the machine with the door open. The machine should not start with the door open.
  - b. Close and lock the door and start a cycle. Attempt to open the door while the cycle is in progress. The door should not open.

If the door lock and interlock are not functioning properly, call a service technician.

3. Do not attempt to operate the machine if any of the following conditions are present:
  - a. The door does not remain securely locked during the entire cycle.
  - b. Excessively high water level is evident.
  - c. Machine is not connected to a properly grounded circuit.

Do not bypass any safety devices in the machine.

	<b>WARNING</b>
<b>Never operate the machine with a bypassed or disconnected balance system. Operating the machine with severe out-of-balance loads could result in personal injury and serious equipment damage.</b>	

**SAVE THESE INSTRUCTIONS**

## Technical data and dimensions

3

### Technical data HF455, IHF455, IHF100, IS100, CHF100, CS100

	METRIC	US
<b>Capacity (dry weight) Ratio [kg/Lit]</b>		
	1:11	41,4 kg / 91.27 lb.
	1:10	45,5 kg / 100.31 lb.
	1:9	50,5 kg / 111.33 lb.
<b>Cylinder</b>		
Diameter	980 mm	38.58 inch
Depth	597 mm	23.50 inch
Volume	455 Lit	16.07 ft <sup>3</sup>
<b>Cabinet</b>		
Height	1920 mm	75.59 inch
Width	1200 mm	47.24 inch
Depth	1340 mm	52.76 inch
<b>Front loading</b>		
Diameter door opening	500 mm	19.69 inch
Height under door	638 mm	25.12 inch
To center	960 mm	37.80 inch
<b>Speed</b>		
Wash	10 - 50 tr/min - RPM	
Spin	250 - 800 tr/min - RPM	
<b>G-factor</b>		
High spin	350	
<b>Dynamic bottom load (N/Hz)</b>		
	2960/13	
<b>Motor (3-phase)</b>		
	4p. 1470 tr/min	5,5 kW / 7,37 HP
<b>Drain valve</b>		
	3"	
<b>Water supply</b>		
	Hard, soft, warm water	4x3/4"
<b>Steam connection</b>		
	Steam connection	1/2"
<b>Heating</b>		
Electrical 230/400 V	27 kW	
Electrical 400V	27 kW - 36 kW	
Steam	6 bar	
Warm water (without additional heating)	X	
Warm water (with additional heating)	X	
<b>Packing dimensions</b>		
(H x W x D) mm - inch	2130x1300x1430 mm - 83.86x51.18x56.30 inch	
<b>Weight</b>		
Net	1597 kg	3520.78 lb.
Gross	1697 kg	3741.24 lb.

3

### Dimensions HF455, IHF455, IHF100, IS100, CHF100, CS100

Legend: metric mm [inches]

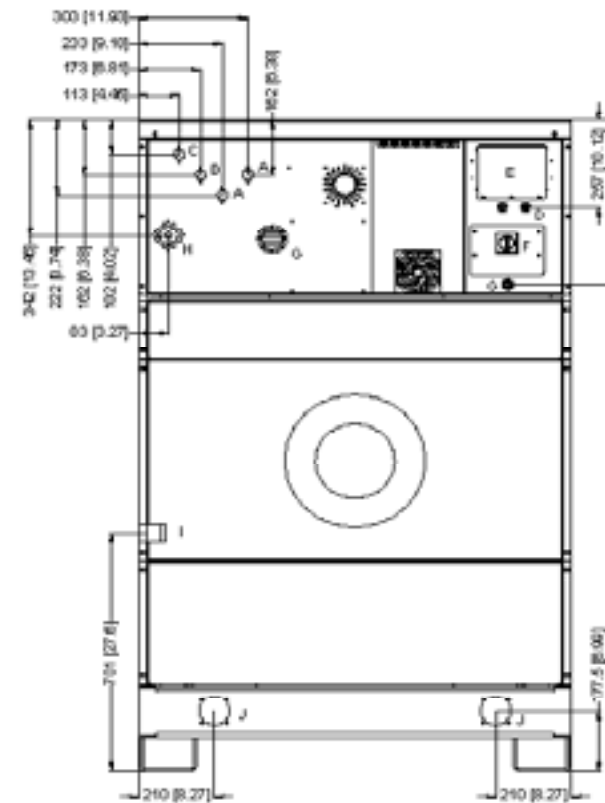
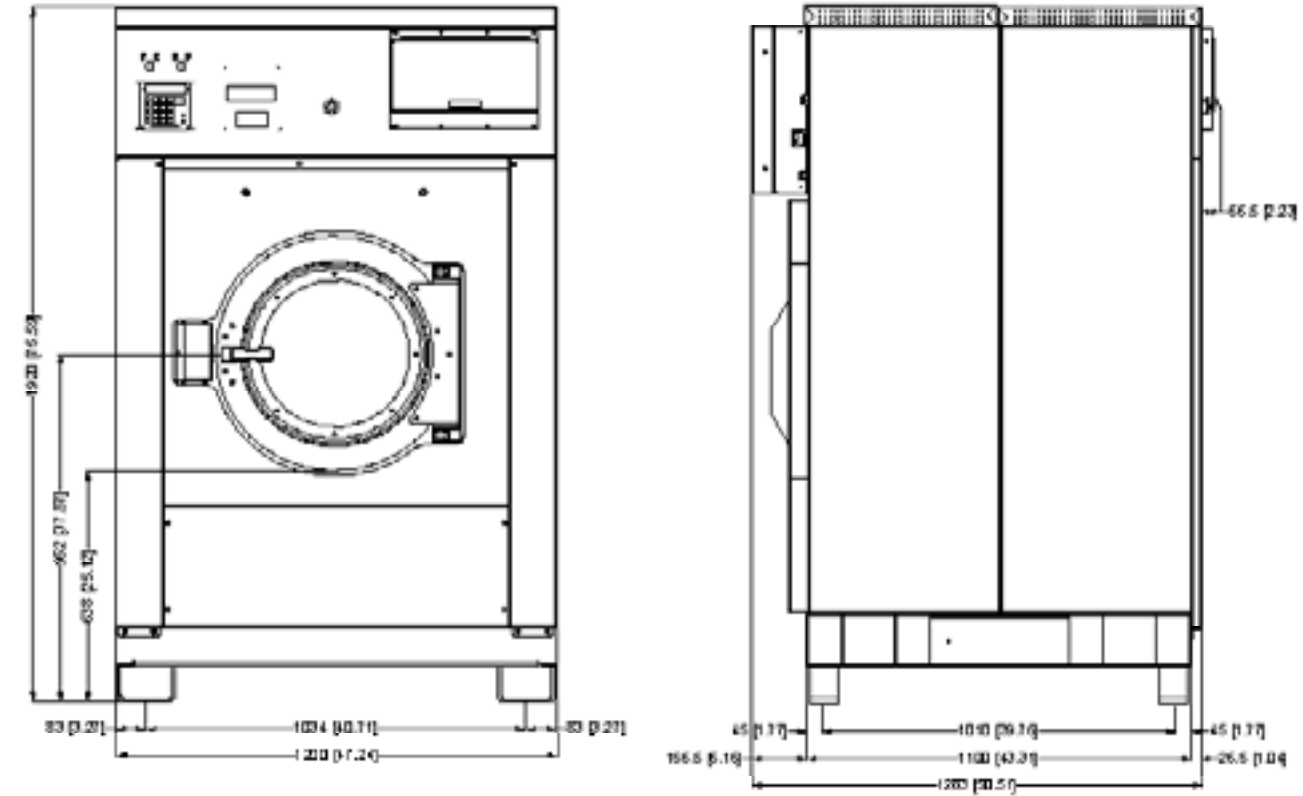

- A. Soft water connection 3/4"
- B. Warm water connection 3/4"
- C. Hard water connection 3/4"
- D. Electrical connection
- E. Electrical connection clamps
- F. Main switch
- G. Ventilation cabinet
- H. Ventilation
- I. Steam connection 1/2"
- J. Drain valve

Technical data HF575, IHF575, IHF135, IS135, CHF135, CS135

	METRIC	US
<b>Capacity (dry weight) Ratio [kg/Lit]</b>		
	1:11	52,3 kg / 115.30 lb.
	1:10	57,5 kg / 126.77 lb.
	1:9	63,8 kg / 140.65 lb.
<b>Cylinder</b>		
Diameter	980 mm	38.58 inch
Depth	775 mm	30.51 inch
Volume	575 Lit	20.31 ft³
<b>Cabinet</b>		
Height	1920 mm	75.59 inch
Width	1200 mm	47.24 inch
Depth	1510 mm	59.45 inch
<b>Front loading</b>		
Diameter door opening	500 mm	19.69 inch
Height under door	638 mm	25.12 inch
To center	960 mm	37.80 inch
<b>Speed</b>		
Wash	10 - 50 tr/min - RPM	
Spin	250 - 800 tr/min - RPM	
<b>G-factor</b>		
High spin	350	
<b>Dynamic bottom load (N/Hz)</b>		
	3900/13	
<b>Motor (3-phase)</b>		
	4p. 1470 tr/min	7,5 kW / 10,05 HP
<b>Drain valve</b>		
	3"	
<b>Water supply</b>		
	Hard, soft, warm water	4x3/4"
<b>Steam connection</b>		
	Steam connection	1/2"
<b>Heating</b>		
Electrical 230/400 V	27 kW	
Electrical 400V	27 - 36 kW	
Steam	6 bar	
Warm water (without additional heating)	X	
Warm water (with additional heating)	X	
<b>Packing dimensions</b>		
(H x W x D) mm - inch	2130x1300x1630 mm - 83.86x51.18x64.17 inch	
<b>Weight</b>		
Net	1787 kg	3939.66 lb.
Gross	1887 kg	4160.12 lb.

Dimensions HF575, IHF575, IHF135, IS135, CHF135, CS135

Legend: metric mm [inches]

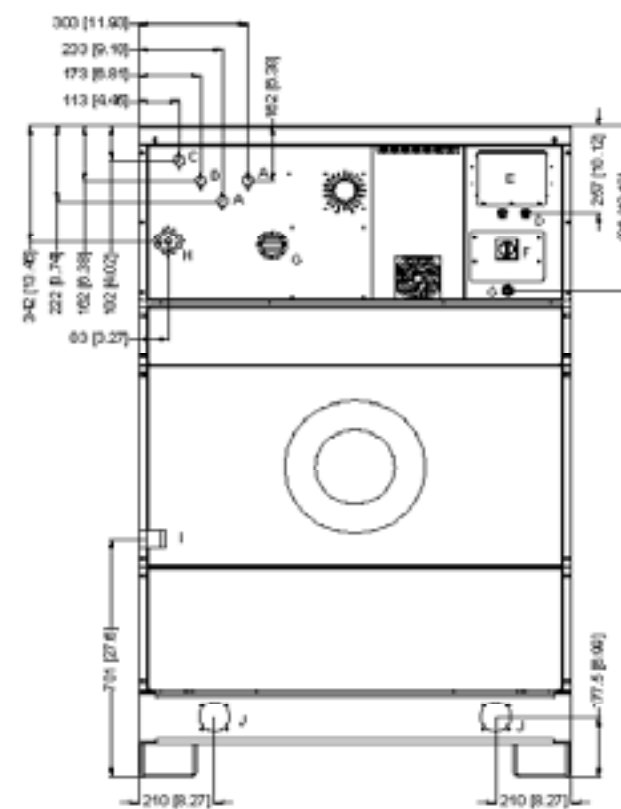
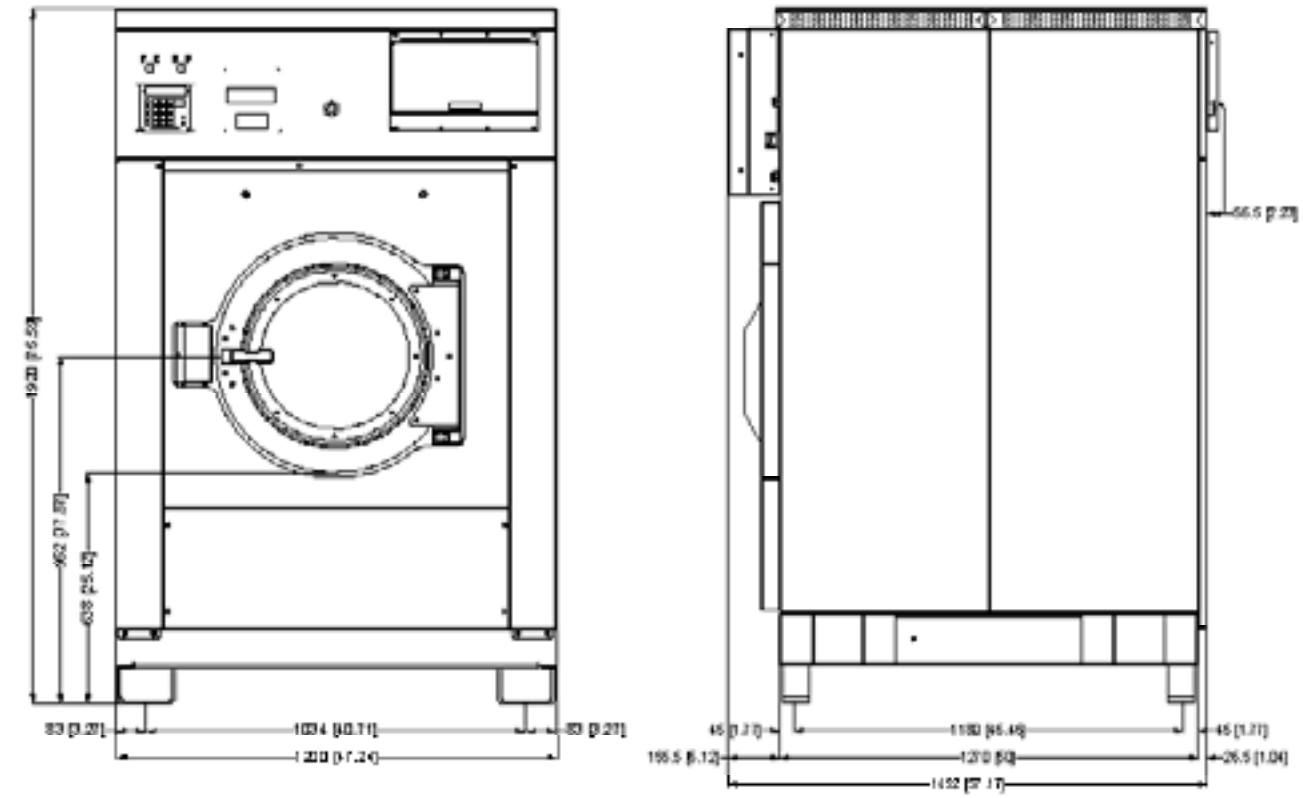

- A. Soft water connection 3/4"
- B. Warm water connection 3/4"
- C. Hard water connection 3/4"
- D. Electrical connection
- E. Electrical connection clamps
- F. Main switch
- G. Ventilation cabinet
- H. Ventilation
- I. Steam connection 1/2"
- J. Drain valve



Technical data HF730, IHF730, IHF165, IS165, CHF165, CS165

	METRIC	US
<b>Capacity (dry weight) Ratio [kg/Lit]</b>		
	1:11	66,4 kg / 146.39 lb.
	1:10	73 kg / 160.94 lb.
	1:9	81,1 kg / 178.79 lb.
<b>Cylinder</b>		
Diameter	1095 mm	43.11 inch
Depth	775 mm	30.51 inch
Volume	730 Lit	25.78 ft³
<b>Cabinet</b>		
Height	2100 mm	82.68 inch
Width	1300 mm	51.18 inch
Depth	1628 mm	64.09 inch
<b>Front loading</b>		
Diameter door opening	622 mm	24.49 inch
Height under door	603 mm	23.74 inch
To center	992,5 mm	39.07 inch
<b>Speed</b>		
Wash	10 - 50 tr/min - RPM	
Spin	250 - 750 tr/min - RPM	
<b>G-factor</b>		
High spin	350	
<b>Dynamic bottom load (N/Hz)</b>		
	4960/13	
<b>Motor (3-phase)</b>		
	4p. 1470 tr/min	11,5 kW / 15,42 HP
<b>Drain valve</b>		
	2x3"	
<b>Water supply</b>		
Hard, soft, warm water	1x3/4" + 3x1"	
<b>Steam connection</b>		
Steam connection	3/4"	
<b>Heating</b>		
Electrical 230/400 V	27 kW	
Electrical 400V	27 kW - 36 kW	
Steam	6 bar	
Warm water (without additional heating)	X	
Warm water (with additional heating)	X	
<b>Packing dimensions</b>		
(H x W x D) mm - inch	2250x1400x1800 mm - 88.58x55.12x70.87 inch	
<b>Weight</b>		
Net	2250 kg	4960.40 lb.
Gross	2350 kg	5180.86 lb.

Dimensions HF730, IHF730, IHF165, IS165, CHF165, CS165

Legend: metric mm [inches]

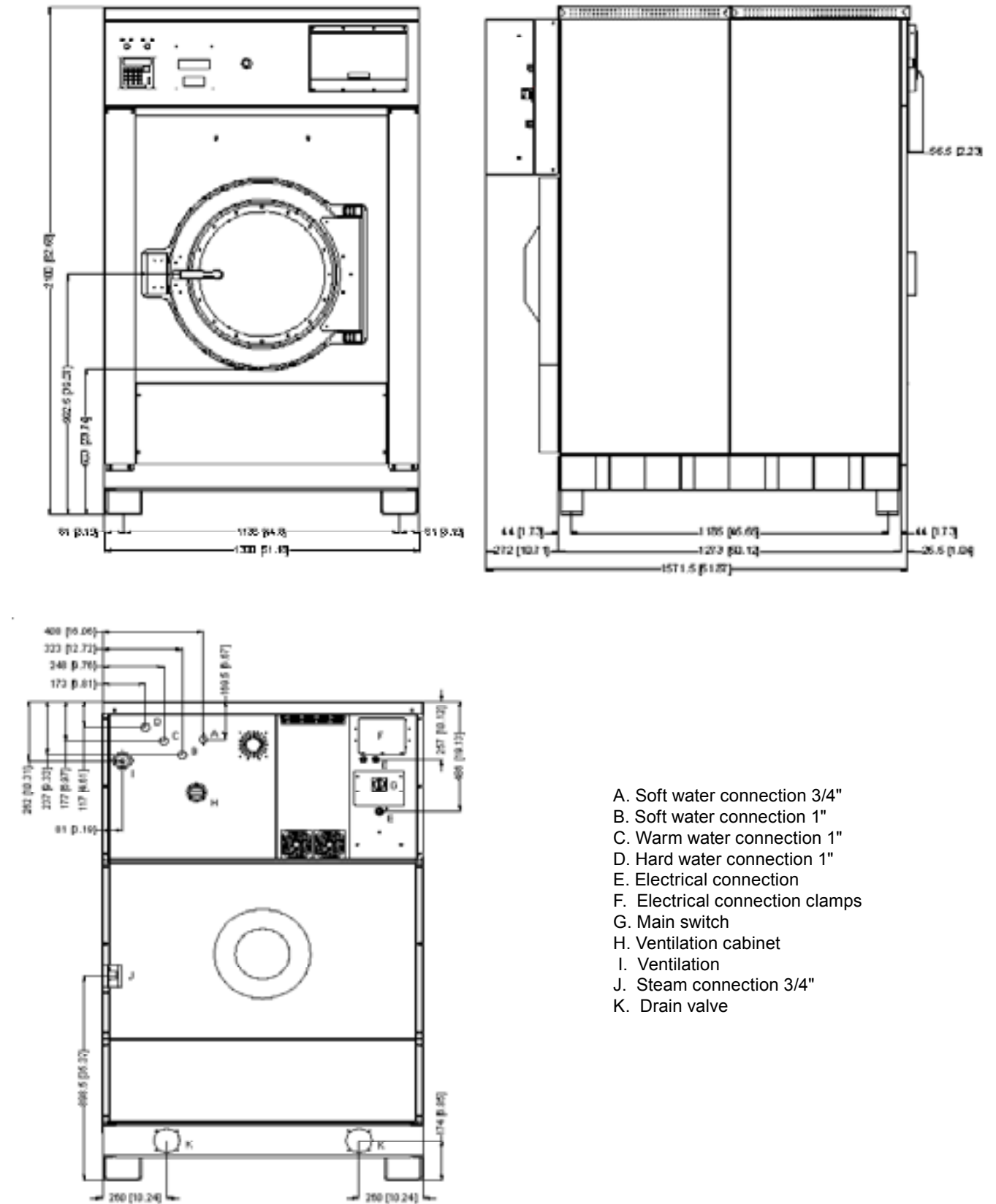

Technical data HF900, IHF900

	METRIC	US
<b>Capacity (dry weight) Ratio [kg/Lit]</b>		
	1:11	81,8 kg 180.34 lb.
	1:10	90 kg 198.42 lb.
	1:9	100 kg 220.46 lb.
<b>Cylinder</b>		
Diameter	1095 mm	43.11 inch
Depth	957 mm	37.68 inch
Volume	900 Lit	31.78 ft³
<b>Cabinet</b>		
Height	2100 mm	82.68 inch
Width	1300 mm	51.18 inch
Depth	1808 mm	71.18 inch
<b>Front loading</b>		
Diameter door opening	622 mm	24.49 inch
Height under door	603 mm	23.74 inch
To center	992,5 mm	39.07 inch
<b>Speed</b>		
Wash	10 - 50 tr/min - RPM	
Spin	250 - 750 tr/min - RPM	
<b>G-factor</b>		
High spin	350	
<b>Dynamic bottom load (N/Hz)</b>		6100/13
<b>Motor (3-phase)</b>		
	4p. 1470 tr/min	11,5 kW / 15,42 HP
<b>Drain valve</b>		2x3"
<b>Water supply</b>		
Hard, soft, warm water	1x3/4" + 3x1"	
<b>Steam connection</b>		
Steam connection	3/4"	
<b>Heating</b>		
Electrical 230/400 V	27 kW	
Electrical 400V	27 kW - 36 kW	
Steam	6 bar	
Warm water (without additional heating)	X	
Warm water (with additional heating)	X	
<b>Packing dimensions</b>		
(H x W x D) mm - inch	2250x1630x2100 mm - 88.58x64.17x82.68 inch	
<b>Weight</b>		
Net	2900 kg	6393.41 lb.
Gross	3000 kg	6613.87 lb.

Dimensions HF900, IHF900

Legend: metric mm [inches]

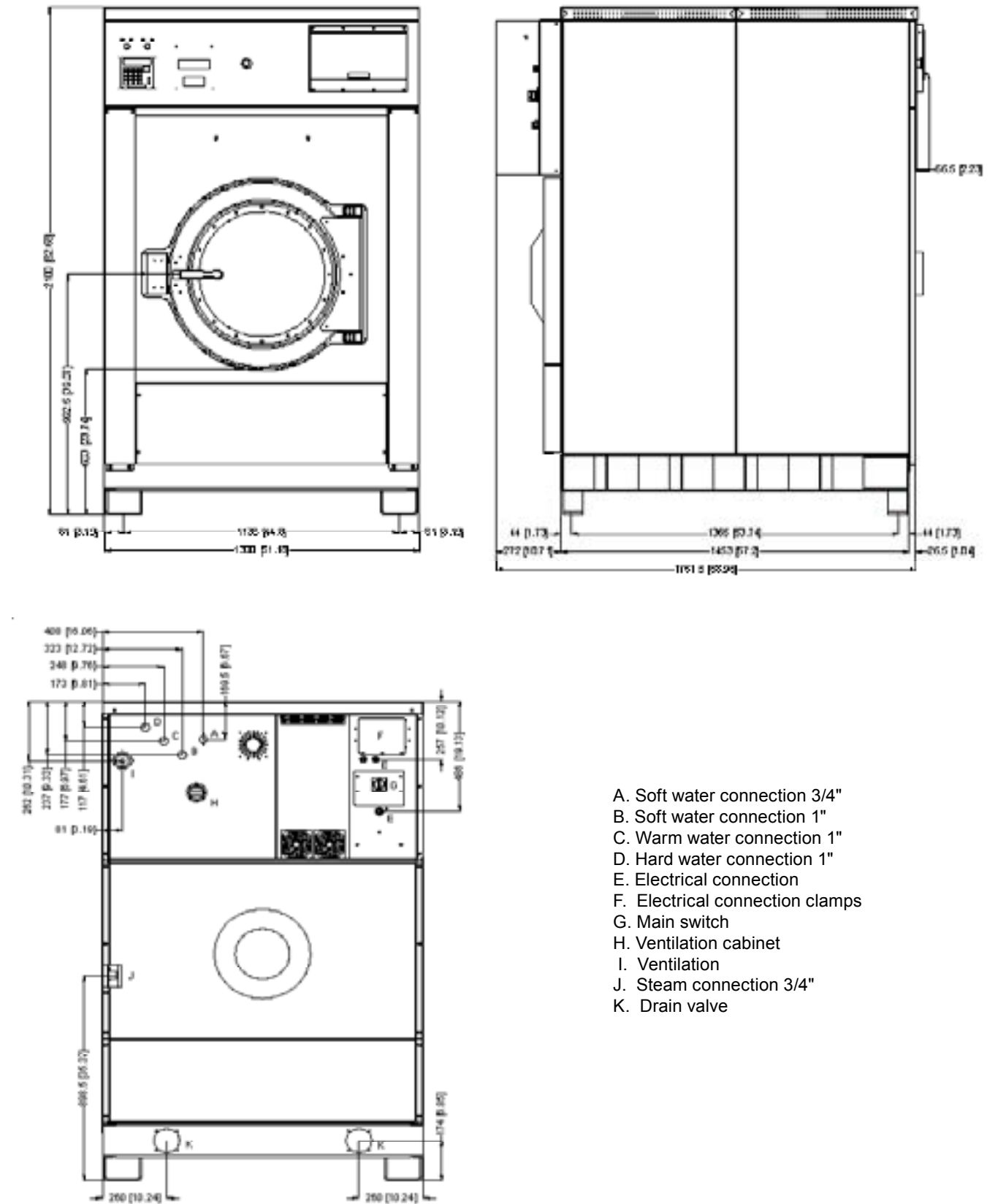

- A. Soft water connection 3/4"
- B. Soft water connection 1"
- C. Warm water connection 1"
- D. Hard water connection 1"
- E. Electrical connection
- F. Electrical connection clamps
- G. Main switch
- H. Ventilation cabinet
- I. Ventilation
- J. Steam connection 3/4"
- K. Drain valve

**CAUTION**

Ensure that the machine is installed on a level floor of sufficient strength and that the recommended clearances for inspection and maintenance are provided. Never allow the inspection and maintenance space to be blocked.

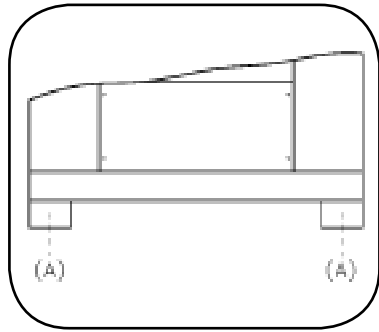

Label 1

**Surface**

The machine must be placed on a flat, solid surface (metal base, concrete or solid ground). When using a metal base or with machines with steam heating, **the machine must be anchored** on the 4 provided locations (A) (See Label 1) in the base. (See Mounting Bolt Hole Locations). The height of the pad should not exceed 203 mm - 8 inch.

The machine must be placed entirely level. For easy maintenance it is recommended to keep a minimal distance of 600 mm - 23.62 inch between the wall and the back of the machine.

If several machines are placed next to each other, there should be a minimal distance of 30 mm - 1.18 inch between each machine.

**Removal of the transport safety**

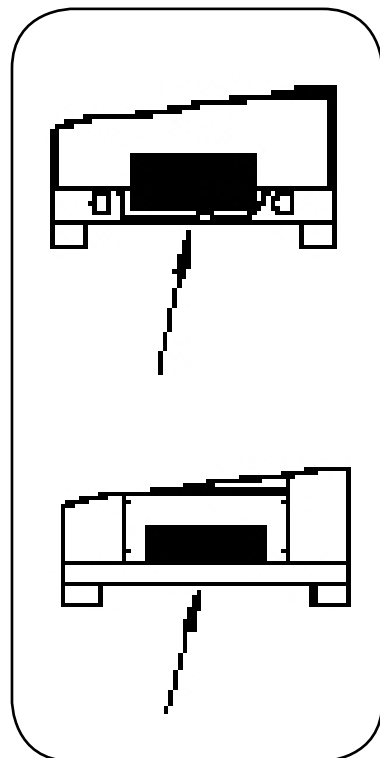

Label 2

To prevent damage during transportation, the machine has been equipped with four red transport brackets to eliminate every possible movement of the tub.

After the machine has been placed level, take off the service panel and back panel to remove these transport brackets. (See Label 2)

**Important**

The machine must never be activated **before removing these transport brackets**. If the machine needs to be moved from the installed location, first reinstall the four red transport brackets.

**Mounting Bolt Hole Locations for machines, HF455, IHF455, IHF100, IS100, CHF100, CS100**

Legend: metric mm [inches]

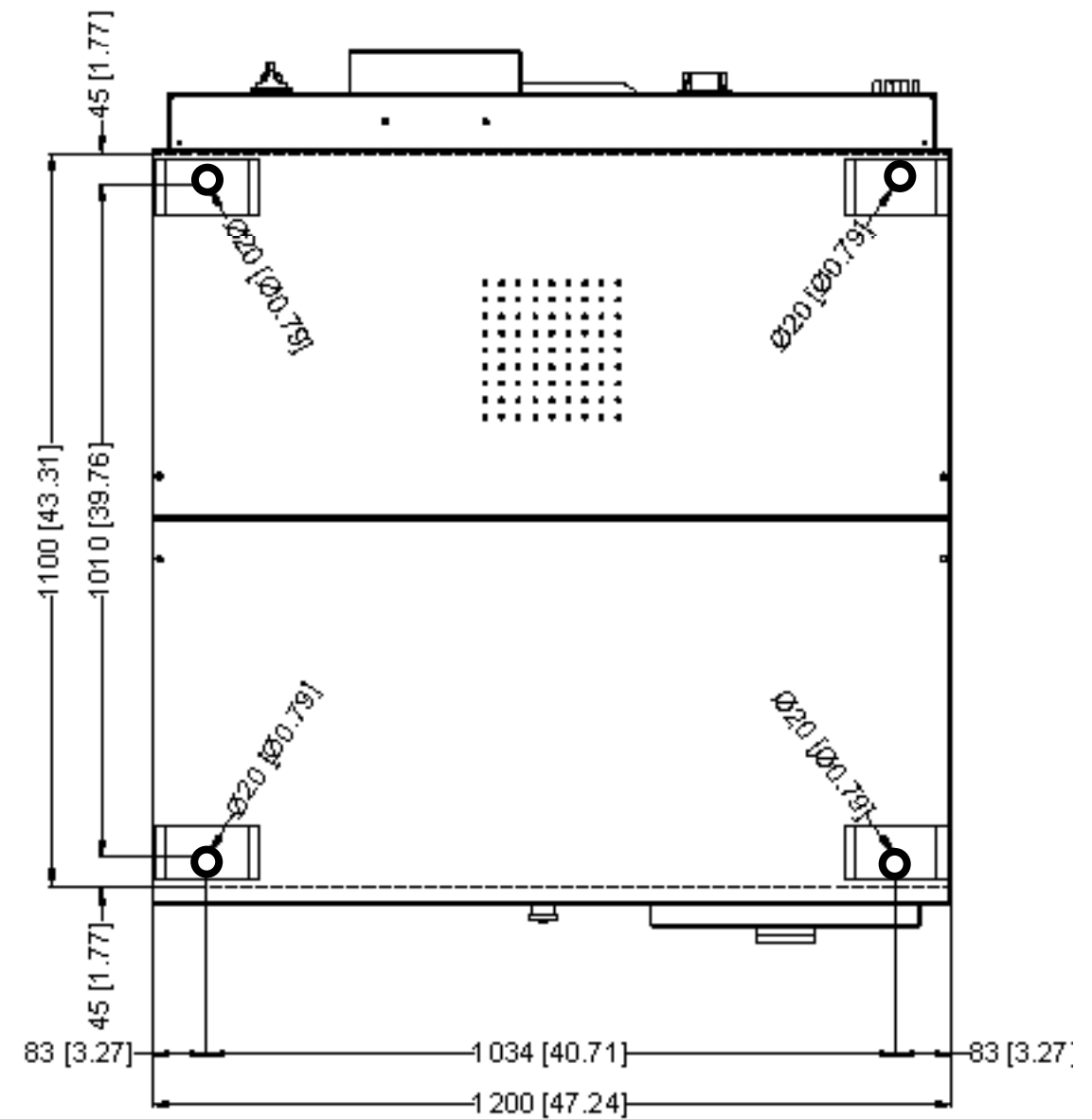

**Mounting Bolt Hole Locations for machines, HF575, IHF575, IHF135, IS135, CHF135, CS135**

Legend: metric mm [inches]

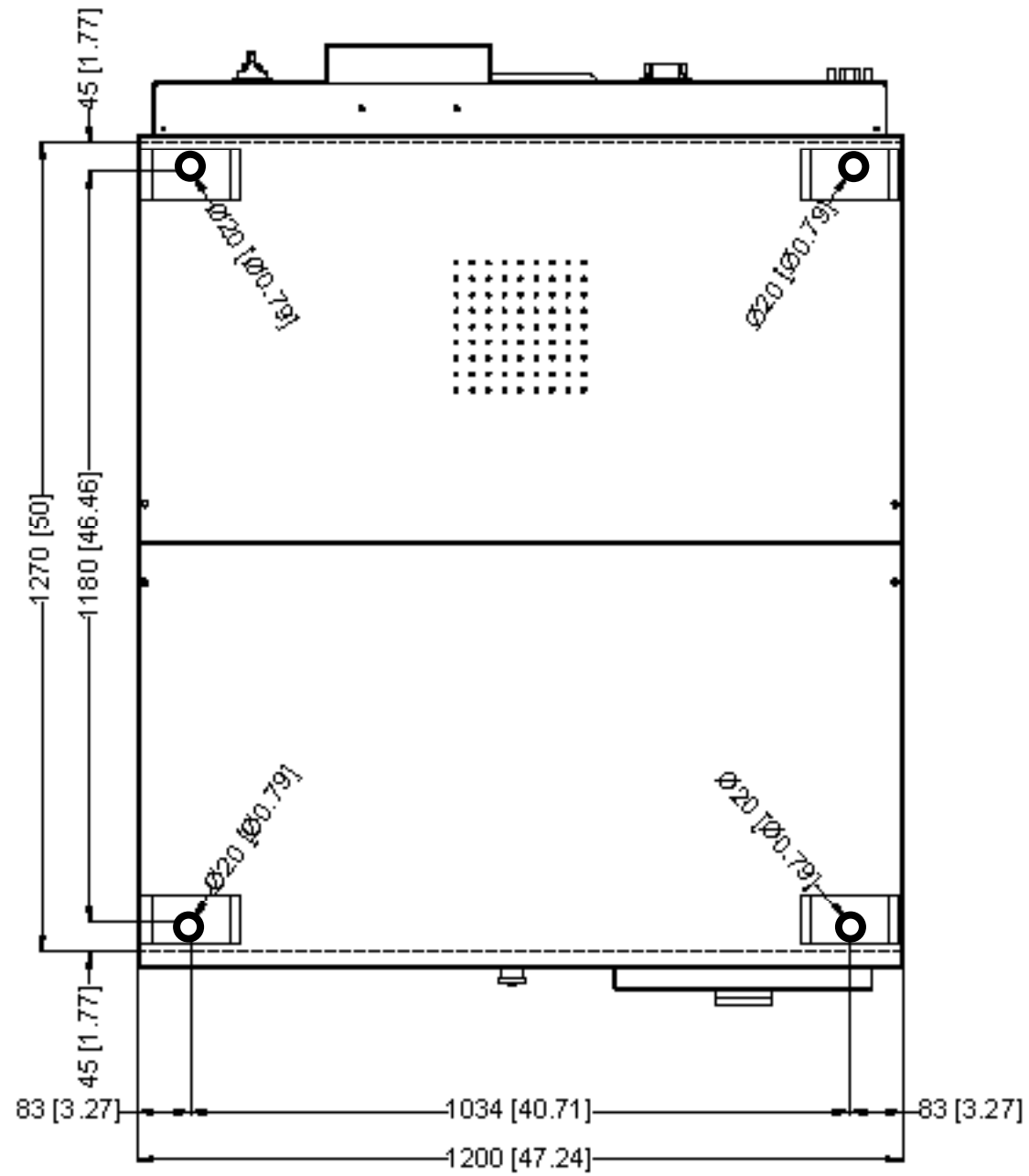

**Mounting Bolt Hole Locations for machines, HF730, IHF730, IHF165, IS165, CHF165, CS165**

Legend: metric mm [inches]

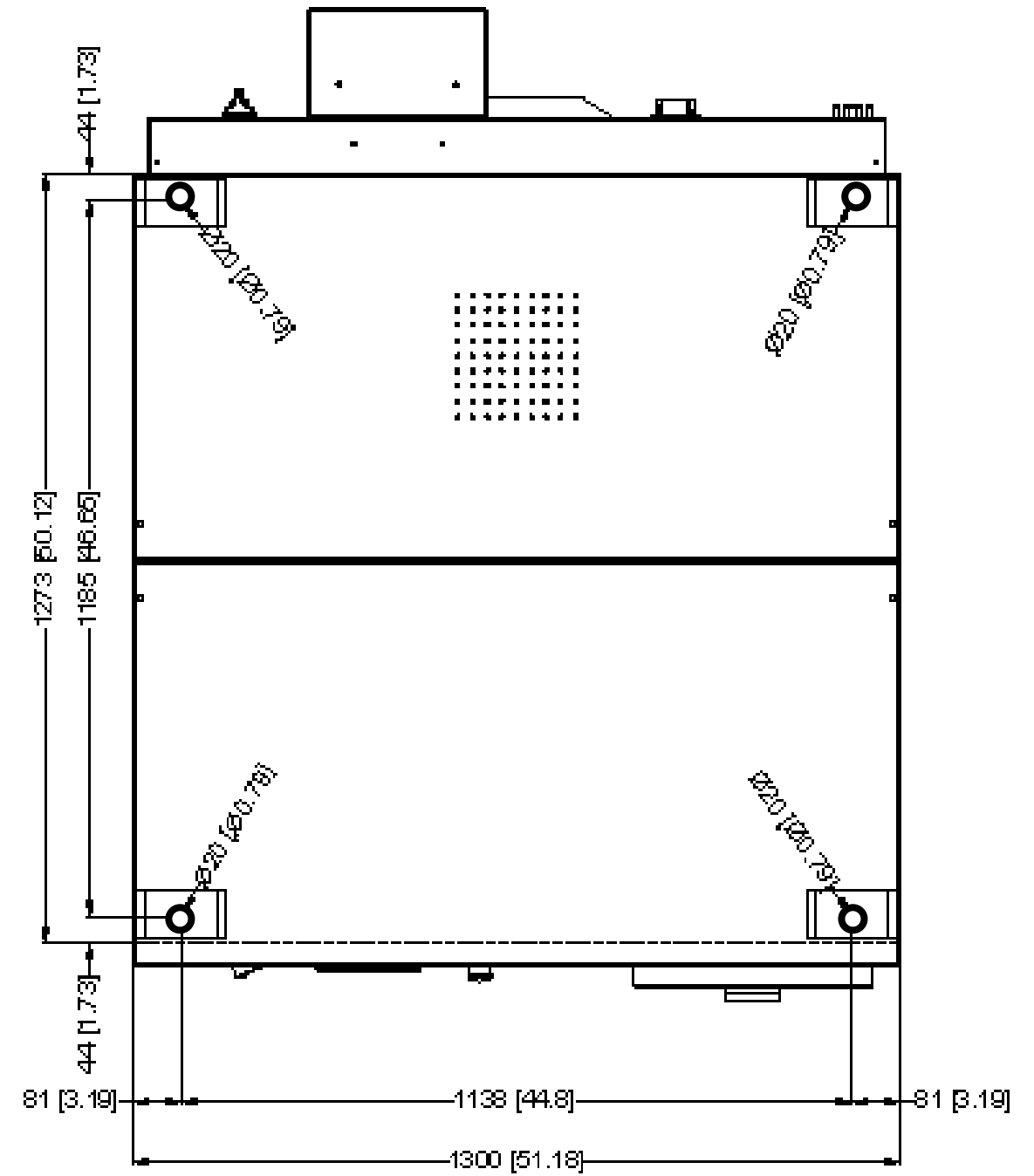

**Mounting Bolt Hole Locations for machines, HF900, IHF900**

Legend: metric mm [inches]

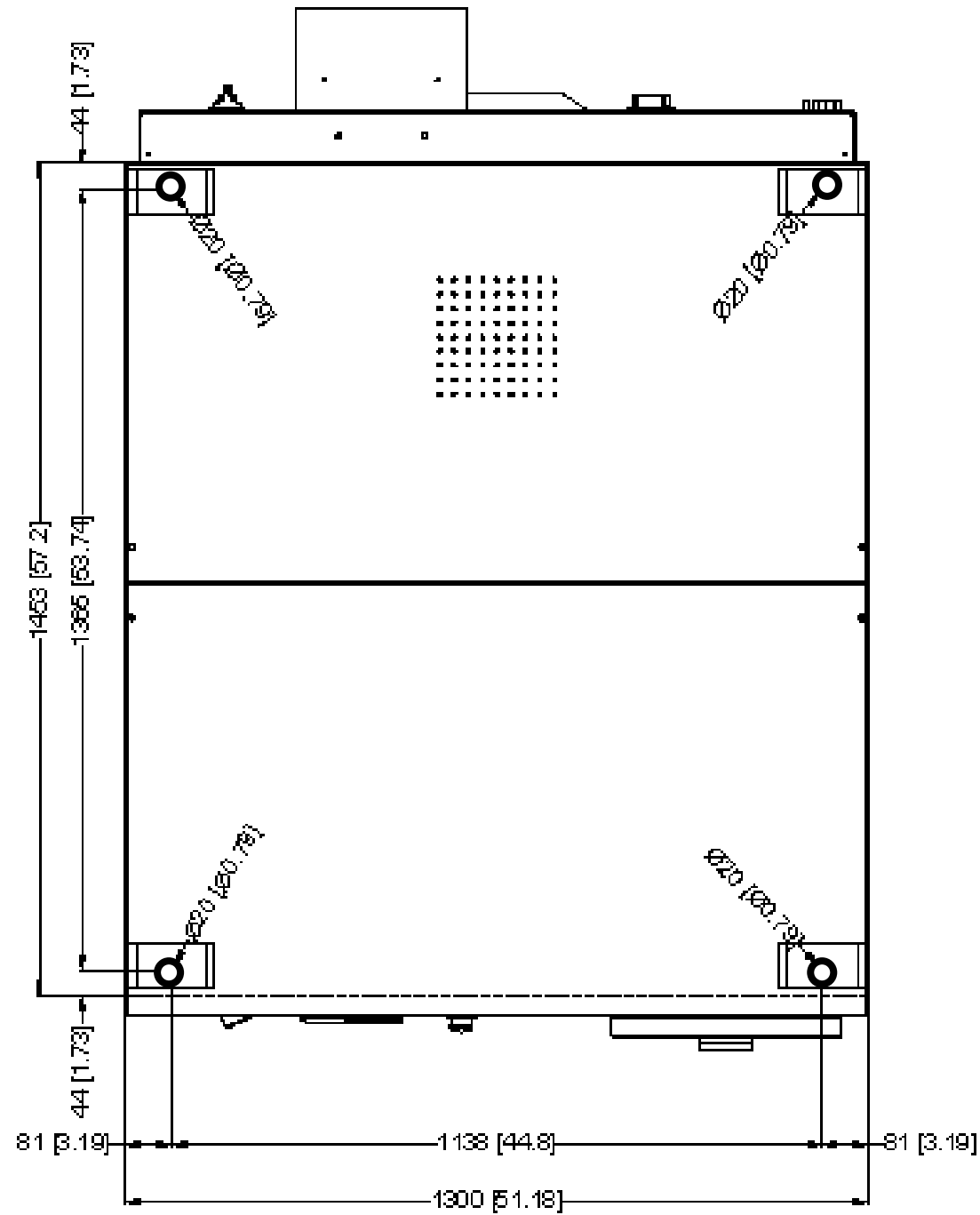

**Water connection**

The machine is delivered with hoses with 3/4" connections (HF455-575) and with 1x3/4" + 3x1" connections (HF730-900). These hoses fit the water inlet valves of the machine and the main water inlet taps. All the inlet valves have to be connected. To ensure the optimal functioning of the water inlet valves, the water pressure on the inlet should be between 3 and 5 bar (40 and 80 psi). If the pressure is too low, the cycle time will increase considerably.

Inlet flow capacity per minute (gallons / liters): 7.93 + 13.2 / 30 + 50.

In case of boiler fed machines, a minimum of hot water of 90°C - 194°F should be available per unit. (See Table 1)

MODEL	Min Contents Boiler	
	METRIC	US
For the HF455, IHF455, IHF100, IS100, CHF100, CS100	350 l.	12.36 ft³
For the HF575, IHF575, IHF135, IS135, CHF135, CS135	445 l.	15.72 ft³
For the HF730, IHF730, IHF165, IS165, CHF165, CS165	566 l.	19.99 ft³
For the HF900, IHF900	566 l.	19.99 ft³

Table 1

**Water drain**

The machine is equipped with a drain valve with 3" outer diameter (80 mm) for HF455-575 and with 2x3" outer diameter (2x80 mm) for HF730-900. This drain valve should be connected to the drain by means of the drain elbow which is delivered with the machine.

The diameter of the main drain should be adapted to the water flow and the number of machines. It should be sufficient to handle at least 160 l/min - 42.26 gal./min per machine.

It is necessary to connect the main drain at least on one side to an open air-brake to allow ventilation.

When the main drain has not been sufficiently deodorized, every machine should be installed separately with a deodorizer.

## Electrical Installation

### Important

Electrical ratings are subject to changes. Refer to serial plate decal for electrical ratings information specific to your machine.

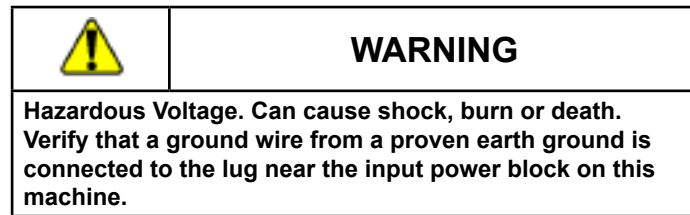
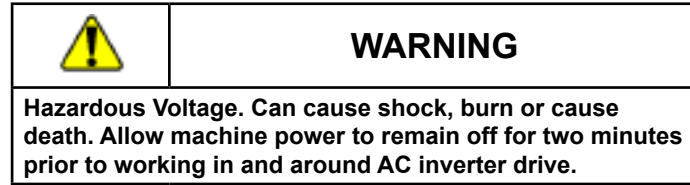

The AC inverter drive requires a clean power supply free from voltage spikes and surges. If a transformer or generator is connected to the building's power supply, always install line reactors before the terminal block connections to the machine. A voltage monitor should be used to check incoming power. The customer's local power company may provide such a monitor.

If input voltage measures above 240V for a 220V drive or above 480V for a 400V drive, ask the power company to lower the voltage. As an alternative, a step-down transformer kit is available from the distributor.

The AC drive provides overload protection for the drive motor. However, a separate single or three-phase circuit breaker must be installed for complete electrical overload protection. This prevents damage to the motor by disconnecting all legs if one should be lost accidentally. Check the data plate on the back of the washer-extractor or consult Table 2 through 5 for circuit breaker requirements.

### **IMPORTANT: Do NOT use fuses in place of a circuit breaker.**

For installation in the United States or Canada, branch circuit protection must be provided according to National and Local Codes. The branch circuit breaker must be of the inverse time or instantaneous trip type at the values given in the technical specifications for each machine. Use a circuit breaker of the minimal type of 10kA interrupt current.



The washer-extractor should be connected to an individual branch circuit not shared with lighting or another electrical device.

The connection should be shielded in a liquid tight or approved flexible conduit with proper conductors of correct size installed in accordance with the National Electric Code or other applicable codes. The connection must be made by a qualified electrician using the wiring diagram provided with the washer-extractor, or according to accepted European standards for CE-approved equipment.

Use wire sizes indicated in Table 2 through 5 for runs up to 50 feet.

Use next larger size for runs of 50 to 100 feet. Use two sizes larger for runs greater than 100 feet.

For personal safety and proper operation, the washer-extractor must be grounded in accordance with state and local standards. If such standards are not available, grounding must conform to the National Electric Code, article 250-95. The ground connection must be made to a proven earth ground, not to a water pipe, gas pipe, or another metal pipe. Provide the necessary equipotential connections according to the local electrical prescriptions.

### GROUNDING INSTRUCTIONS

This appliance must be connected to a grounded metal, permanent wiring system; or an equipment-grounding conductor must be run with the circuit conductors and connected to the equipment-grounding terminal or lead on the appliance.

**IMPORTANT: Alliance Laundry Systems Warranty does not cover components that fail as a result of improper input voltage.**

## Main power connection

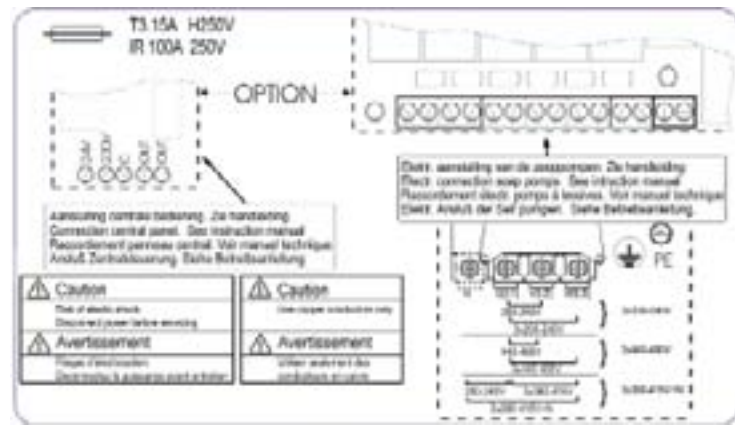

Label 3

### Connection label:

Machine power connections are made at the back of the machine. Three or four conductor power cable is the recommended method (See chapter electrical specs for minimum cable requirements, if local electrical codes exceed these requirements, follow local codes). The number of conductors in this cable and the proper connection points for the cable wires shall be determined by the machine and power requirements. All machines must have a ground wire and be properly grounded. The ground wire must be insulated with a green/yellow color. This wire is normally within the power cable but can also be a separate wire run along side the power cable if properly sized.

Never run a machine that does not have a ground wire. This ground wire must be connected to the machine grounding lug found near the main switch. This lug is identified with the international “protective earth” symbol and the letters “PE”. Failure to connect this ground wire can lead to an unsafe machine condition leading to machine damage and/or operator injury or death. This wire must be connected to earth ground at far end.

### Machine Power Cable Connections:

Remove main switch cover plate at back of machine (see chapter dimensions part (F)). Run power cable through the cabinet knock-out located directly below the cover plate. Before installing, obtain and install a cord-grip to hold the cable in place. Never rely upon the electrical connections to hold cable in place. Allow some slack in this cable outside of the machine to form a drip-loop between the supply power circuit breaker and the machine knock-out. Connect power cable wires as directed below. Always connect the ground wire first and remove last.

### Wiring based on the supply power and machine design (voltage/frequency):

440-480 Volts, 3-Phase, 3-wire or 4-wire + PE, 50 or 60 Hertz Configuration (Named: N-Voltage):

With supply power of: 440-480 Volts, 3-phase, 3-wire, after connecting the green/yellow PE ground wire, connect one wire to each of the bottom terminals of the power contactor switch marked: “L1,L2,L3”. When this supply power has four wires, connect this 4th wire, identified as a neutral wire, to the bottom terminal of the auxiliary contactor on the power contactor switch marked: “N”. Connect the remaining power wires as first noted.

380-415 Volts, 3-Phase, 4-wire + PE, 50 or 60 Hertz Configuration (Named: P-Voltage):

With supply power of: 380-415 Volts, 3-phase, 4-wire, after connecting the green/yellow PE ground wire, follow the directions of the four wire system for 440-480 Volt configuration.

200-240 Volts, 3-Phase, 3-wire + PE, 50 or 60 Hertz Configuration (Named: Q-Voltage or 3-phase X-Voltage):

With supply power of: 200-240 Volts, 3-phase, 3-wire, after connecting the green/yellow PE ground wire, connect one power wire to each of the terminals at the bottom of the power contactor switch marked: “L1,L2,L3”.

200-240 volts, 1-Phase, 2-wire + PE, 50 Hertz (called 1-phase, 50 Hz X-voltage):

With supply power of: 200-240 Volts, 1-phase, 2-wire, 50Hz, after connecting the green/yellow PE ground wire, connect the power wire to the “L1” bottom terminal of the power contactor switch and the other wire, identified as the neutral wire, to the bottom terminal of the auxiliary contactor on the power contactor switch marked: “N”.

200-240 volts, 1-Phase, 2-wire + PE, 60 Hertz (called 1-phase, 60 Hz X-voltage):

With supply power of: 200-240 Volts, 1-phase, 2-wire, 60Hz, after connecting the green/yellow PE ground wire, connect one power wire to the “L1” and power wire to the “L2” of the bottom terminals of the power contactor switch.

After connection, check the **spin direction**. The cylinder must spin in the **clockwise direction**.

A wrong spin direction can damage the motor and can also cause water to spurt from the soap dispenser.

In case of **wrong spin direction**: switch the terminal clamps of the motor circuit “R” and “S” of the connecting cable or change the connection at the terminal block switching the L1 and L2 wires.

	<b>WARNING</b>
The washer-extractor should be connected to an individual branch circuit not shared with lighting or other equipment.	

**Electrical Specifications HF455, IHF455, IHF100, IS100, CHF100, CS100**

455 liters / 100 pounds													
Code	Voltage	Cycle	Phase	Wire	Boiler Fed/Steam Heat				Electric Heat				
					Full Load Amps	Recommended Circuit Breaker (US-market)		kW Standard Heating Elements	Full Load Amps	Recommended Circuit Breaker		AWG/mm <sup>2</sup>	
						US	NON-US			US	NON-US		
N	440-480	50/60	3	3+PE	17	25	25	12/4	9x4 kW	74	N/A	80	4/25
P	380-415	50/60	3	3+N+PE	17	25	25	12/4		74	N/A	80	4/25
Q	200-240	50/60	3	3+PE	23	40	32	10/6	9x3 kW	104	N/A	125	2/40
X	200-240	50/60	1/3	2/3+PE	N/A	N/A	N/A	N/A		N/A	N/A	N/A	N/A
Alternative Electric Heat Options													
N	440-480	50/60	3	3+PE					9x3 kW	61	N/A	70	4/25
P	380-415	50/60	3	3+N+PE						61	N/A	70	4/25
Q	200-240	50/60	3	3+PE						104	N/A	125	2/40
X	200-240	50/60	1/3	2/3+PE						N/A	N/A	N/A	N/A

Table 2

	<b>WARNING</b>
The washer-extractor should be connected to an individual branch circuit not shared with lighting or other equipment.	

**Electrical Specifications HF575, IHF575, IHF135, IS135, CHF135, CS135**

575 liters / 135 pounds													
Code	Voltage	Cycle	Phase	Wire	Boiler Fed/Steam Heat				Electric Heat				
					Full Load Amps	Recommended Circuit Breaker (US-market)		kW Standard Heating Elements	Full Load Amps	Recommended Circuit Breaker		AWG/mm <sup>2</sup>	
						US	NON-US			US	NON-US		
N	440-480	50/60	3	3+PE	27	30	32	10/6.0	9x4 kW	79	N/A	80	4/25
P	380-415	50/60	3	3+N+PE	27	30	32	10/6.0		79	N/A	80	4/25
Q	200-240	50/60	3	3+PE	52	60	60	8/10.0	9x3 kW	120	N/A	125	2/40
X	200-240	50/60	1/3	2/3+PE	N/A	N/A	N/A	N/A		N/A	N/A	N/A	N/A
Alternative Electric Heat Options													
N	440-480	50/60	3	3+PE					9x3 kW	66	N/A	70	4/25
P	380-415	50/60	3	3+N+PE						66	N/A	70	4/25
Q	200-240	50/60	3	3+PE						79	N/A	80	4/25
X	200-240	50/60	1/3	2/3+PE						N/A	N/A	N/A	N/A

Table 3



	<b>WARNING</b>
The washer-extractor should be connected to an individual branch circuit not shared with lighting or other equipment.	

**Electrical Specifications HF730, IHF730, IHF165, IS165, CHF165, CS165**

730 liters / 165 pounds													
Code	Voltage	Cycle	Phase	Wire	Boiler Fed/Steam Heat				Electric Heat				
					Full Load Amps	Recommended Circuit Breaker (US-market)		kW Standard Heating Elements	Full Load Amps	Recommended Circuit Breaker		AWG/mm2	
						US	NON-US			US	NON-US		
N	440-480	50/60	3	3+PE	44	50	50	8/10.0	9x4 kW	96	N/A	100	2/40
P	380-415	50/60	3	3+N+PE	44	50	50	8/10.0		96	N/A	100	2/40
Q	200-240	50/60	3	3+PE	85	90	90	4/25.0	9x3 kW	153	N/A	180	4/0 / 100
X	200-240	50/60	1/3	2/3+PE	N/A	N/A	N/A	N/A		N/A	N/A	N/A	N/A
Alternative Electric Heat Options													
N	440-480	50/60	3	3+PE					9x3 kW	83	N/A	90	2/40
P	380-415	50/60	3	3+N+PE						83	N/A	90	2/40
Q	200-240	50/60	3	3+PE						153	N/A	180	4/0 / 100
X	200-240	50/60	1/3	2/3+PE						N/A	N/A	N/A	N/A

Table 4

	<b>WARNING</b>
The washer-extractor should be connected to an individual branch circuit not shared with lighting or other equipment.	

**Electrical Specifications HF900, IHF900**

900 liters / 200 pounds													
Code	Voltage	Cycle	Phase	Wire	Boiler Fed/Steam Heat				Electric Heat				
					Full Load Amps	Recommended Circuit Breaker (US-market)		kW Standard Heating Elements	Full Load Amps	Recommended Circuit Breaker		AWG/mm2	
						US	NON-US			US	NON-US		
N	440-480	50/60	3	3+PE	44	50	50	8/10.0	9x4 kW	96	N/A	100	2/40
P	380-415	50/60	3	3+N+PE	44	50	50	8/10.0		96	N/A	100	2/40
Q	200-240	50/60	3	3+PE	85	90	90	4/25.0	9x3 kW	153	N/A	180	4/0 / 100
X	200-240	50/60	1/3	2/3+PE	N/A	N/A	N/A	N/A		N/A	N/A	N/A	N/A
Alternative Electric Heat Options													
N	440-480	50/60	3	3+PE					9x3 kW	83	N/A	90	2/40
P	380-415	50/60	3	3+N+PE						83	N/A	90	2/40
Q	200-240	50/60	3	3+PE						153	N/A	180	4/0 / 100
X	200-240	50/60	1/3	2/3+PE						N/A	N/A	N/A	N/A

Table 5

**Automatic lubricator**

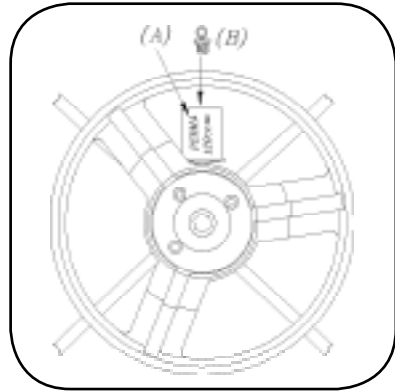

Label 4

The bearing house of the machine is equipped with a lubricating device (A) which automatically lubricates the bearing during one year. Upon delivery of the machine, this lubricator has not been brought into use. To this effect, please put on the matching screw (B) in the foreseen opening of the lubricator. (See Label 4)



Ignoring this instruction will inevitably cause damage to the bearings! Warranty is void if bearings are not lubricated.

**Liquid soap connection (option)**

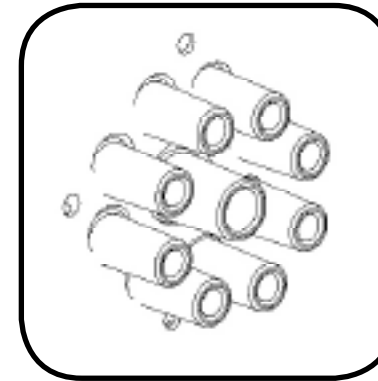

Label 5

**Connection of the liquid soap hoses**

The liquid soap connection consists of **8 connections for liquid soap** (See Label 5).

The central opening is used for ventilation.

	<b>WARNING</b>
<p><b>Dangerous Chemicals. May damage eyes and skin. Wear eye and hand protection when handling chemicals; always avoid direct contact with raw chemicals. Read the manufacturer's directions for accidental contact before handling chemicals. Ensure an eye-rinse facility and an emergency shower are within easy reach. Check at regular intervals for chemical leaks.</b></p>	

<b>CAUTION</b>
<p><b>Drill out plugs and nipples before making supply hose connection. Failure to do so can cause buildup of pressure and risk a tubing rupture.</b></p>

**Electrical connection of the liquid soap pumps**

On machines equipped with a liquid soap connection, connect the wires **directly on the print board** next to the ground wire connection (option). Connect as indicated on the wiring diagram.

The two connectors on the right give a tension of 220V ~ (max. 4A) which can be applied to drive 220V ~ soap pumps. If more than **4A** is required, **an external tension** will have to be used. **6** connections have been provided, of which one (**S6**) can be used to drive a waterproofing pump (e.g. for rain coats, etc.). (See Label 6)

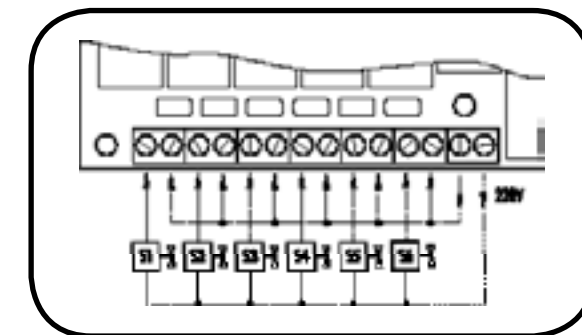

Label 6

The 220V can be transformed to other values to drive other type soap pumps.  
 Example: pumps 24V ~. (See Label 7)

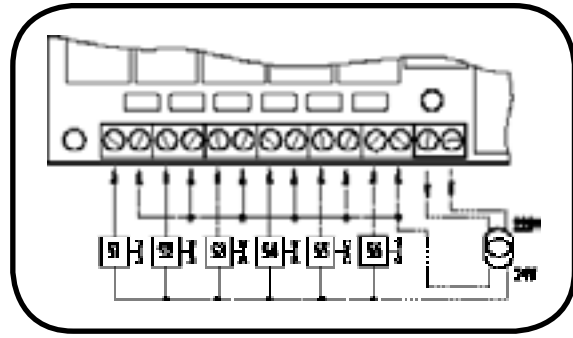

Label 7

Also, pumps with different operating tension can be combined.  
 Example: 5 pumps 220V ~ and 1 pump 24V ~. (See Label 8)

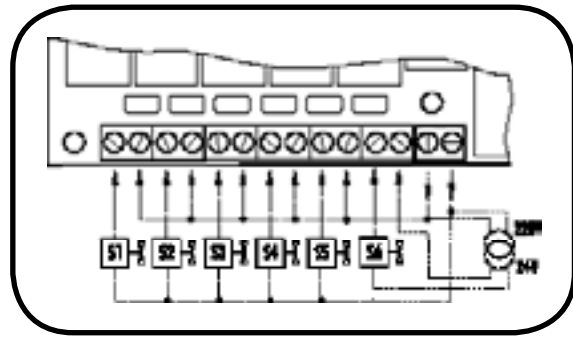

Label 8

With an external tension 24V DC (See Label 9)

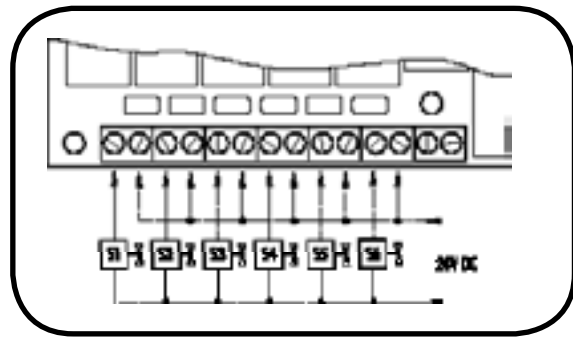

Label 9

**Connection of a central operating panel for coin machines (option)**

	<b>WARNING</b>
<p>To reduce the risk of electric shock, disconnect this appliance from the power supply before attempting any user maintenance. Turning the controls to the OFF position does not disconnect this appliance from the power supply.</p>	

At the backside above the main connectors, you find a printboard, to which the central operating panel for coin machines can be connected.  
 The right connectors form a potential free output contact as a result of which the operating panel detects when the machine is activated or not.  
 The left connectors receive the signal, by means of which a machine is chosen through the operating panel.  
 There are 3 different variations possible according to the output voltage of the operating panel. (See Labels 10, 11 and 12)

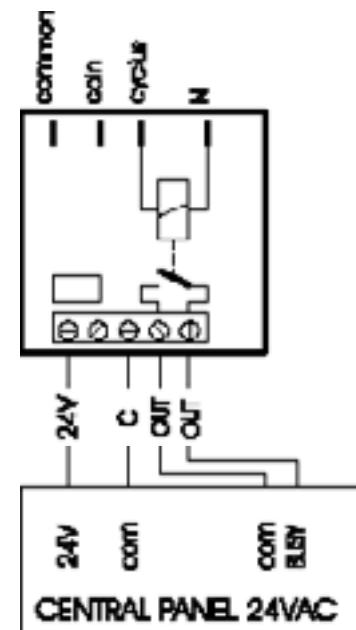

Label 10

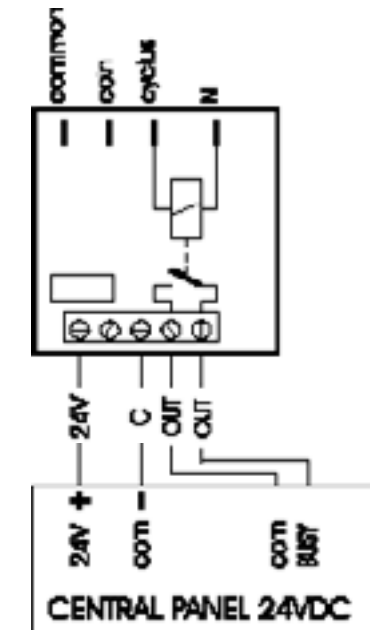

Label 11

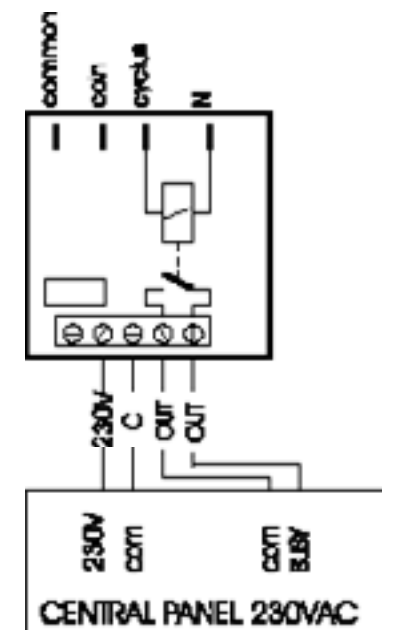

Label 12

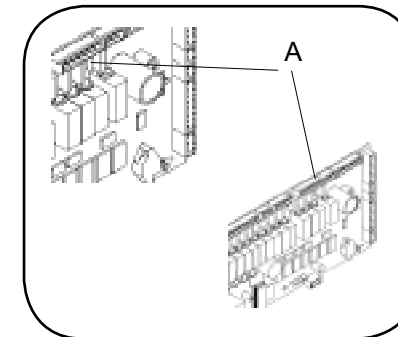

Label 13

**IMPORTANT:**

If a machine is equipped with this kind of printboard or if a printboard has been built in, the **resistance of the cycle contact (A) may no longer be present** on the main printboard. (See Label 13)  
**When this resistance is present, it has to be cut out of the main printboard.**

	<b>WARNING</b>
<p>Never touch internal or external steam pipes, connections, or components. These surfaces can be extremely hot and will cause severe burns. The steam must be turned off and the pipe, connections, and components allowed to cool before the pipe can be touched.</p>	

Machines with steam heating must have a steam valve between the steam installation and the machine.

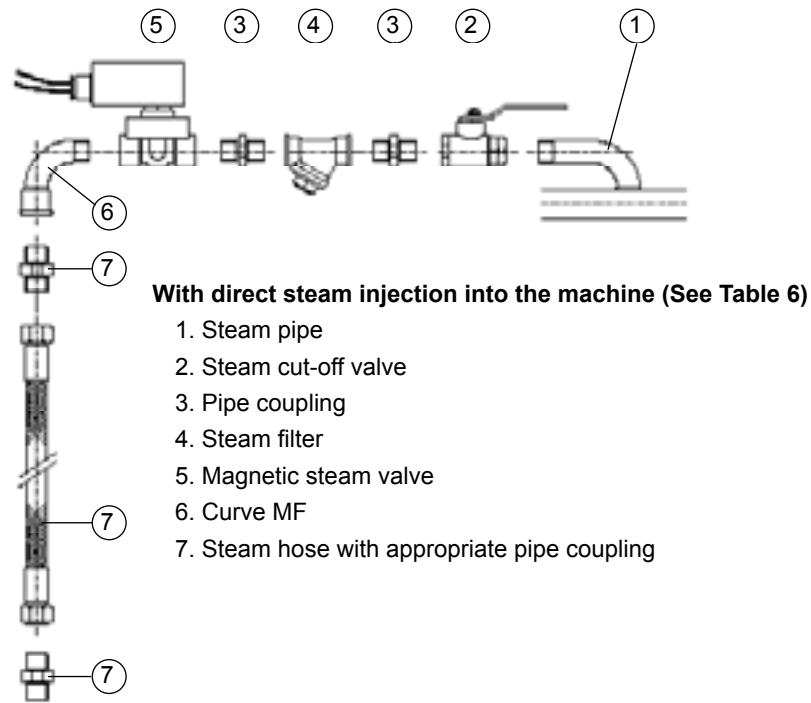

Steam Supply Information							
MODEL	Steam inlet connection, inch	Number of steam inlets	Recommended pressure, bar	Recommended pressure, psi	Maximum pressure, bar	Maximum pressure, psi	
For the HF455, IHF455, IHF100, IS100, CHF100, CS100	1/2	1	2.0 - 5.5	30 - 80	5.5	80	
For the HF575, IHF575, IHF135, IS135, CHF135, CS135	1/2	1	2.0 - 5.5	30 - 80	5.5	80	
For the HF730, IHF730, IHF165, IS165, CHF165, CS165	3/4	1	2.0 - 5.5	30 - 80	5.5	80	
For the HF900, IHF900	3/4	1	2.0 - 5.5	30 - 80	5.5	80	

Table 6

Internal connections of the electrical heating

1 AC

Heating	R5
3kw	LC1D0901

Table 7

3 AC

Heating		3x230V	R5	3x400V	R5
4,2kw	3x1,4kw	See Label 14	LC1D0901	See Label 15	LC1D0901
6kw	3x2kw	See Label 14	LC1D0901	See Label 15	LC1D0901
9kw	3x3kw	See Label 14	LC1D1810	See Label 15	LC1D0901
12kw	3x4kw	-----	-----	See Label 14	LC1D0901
12kw	3x2kw 3x2kw	See Label 14 See Label 14	LC1D1810 LC1D1810	See Label 15	LC1D1810
15kw	3x2kw 3x3kw	See Label 14 See Label 14	LC1D1810 LC1D1810	See Label 15	LC1D1810
18kw	3x3kw 3x3kw	See Label 14 See Label 14	LC1D1810 LC1D1810	See Label 15	LC1D1810
21kw	3x3kw 3x4kw	-----	-----	See Label 15 See Label 14	LC1D1810 LC1D1810
24kw	3x4kw 3x4kw	-----	-----	See Label 14 See Label 14	LC1D1810 LC1D1810
27kw	3x3kw 3x3kw 3x3kw	See Label 14 See Label 14 See Label 14	LC1D1810 LC1D1810 LC1D1810	See Label 15 See Label 15 See Label 15	LC1D1810 LC1D1810 LC1D1810
36kw	3x4kw 3x4kw 3x4kw	-----	-----	See Label 14 See Label 14 See Label 14	LC1D1810 LC1D1810 LC1D1810

Table 8

B = Black    Br = Brown  
Gy = Grey    Bu = Blue  
R = Red      W = White

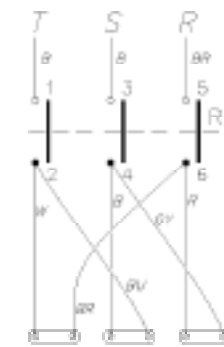

Label 14

"Delta" configuration

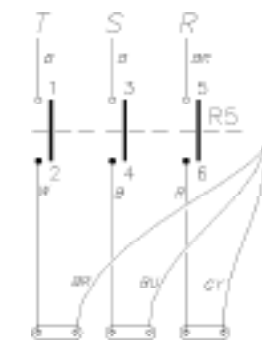

Label 15

"WYE" configuration

**NOTE:**

Other executions are available as options.

**Out of balance switch**

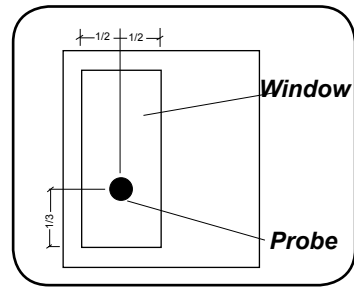

Label 16

The out of balance switch is mounted on the solid part of the machine. There is a window around the probe of the out of balance switch that is mounted on the movable part of the machine.

When the machine goes out of balance by overloading or uneven distribution of the linen, the out of balance switch will interrupt this action to prevent damage to the machine.

**Important**

To guarantee good functioning, the probe should be centered horizontally and vertically at 1/3 from the bottom of the out of balance window (when machine drum is empty). (See Label 16)

**Opening the door in case of an emergency**

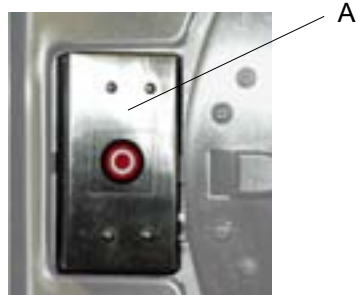

A

To open the door in case of an emergency (deficiencies, etc.), remove the lock cover plate (A). Subsequently, insert a screwdriver from the left-hand side behind the lock mechanism (B) and push back the black handle (C) while opening the doorhandle.

**Important**

Before opening the door, be sure there is no water left in the tub and that the drum has come to a complete stop.



B

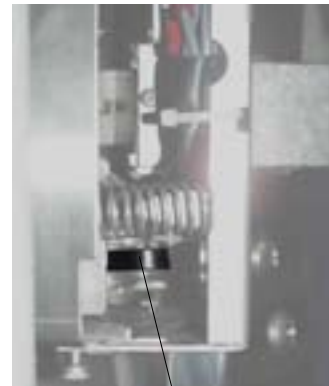

C

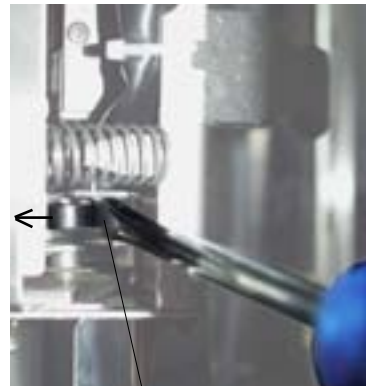

C

**Maintenance instruction of the machine**

	<b>WARNING</b>
<p>To reduce the risk of electric shock, disconnect this appliance from the power supply before attempting any user maintenance. Turning the controls to the OFF position does not disconnect this appliance from the power supply.</p> <p>Before starting wiring or inspection, power must be switched OFF, check to make sure that the operation panel indicator is off. Any person who is involved in wiring or inspection shall wait for at least 10 minutes after the power supply has been switched OFF and check that there is no residual voltage using a tester or the like. The capacitor of the inverter or the EMC filter is charged with a high voltage for some time after power OFF, and it is dangerous.</p>	

**End of day**

Clean AC drive filter:

- a. Snap off external plastic cover which contains filter.
- b. Remove foam filter from cover.
- c. Wash filter with warm water and allow to air dry. Filter can be vacuumed clean.

**General maintenance**

Clean the entire cabinet of the machine regularly and remove all traces of soap, etc....

Remove all detergent residue in the soap dispenser with hot water.

Clean the door gasket and remove all detergents and other products.

Shut off the main water, steam, and power connections at the end of each day.

Do not change the setting of the water inlet taps on boiler fed machines once these have been installed.

It is recommended to leave the door and soap dispenser open after use, to ventilate the machine.

Check for proper door lock operation on a daily basis.

**Periodical maintenance**

The V-belts of the motors should be retightened after two to three months when first used. This is necessary because these belts are subject to a one-time stretching when first used. **If this is not done**, the belt starts to slip after a few months and will break shortly afterwards.

Check the water inlet filters to make sure they are not blocked by calcification.

Check the drain valve for obstructions.

If a machine frequently skips the final spin, check whether the probe of the out of balance switch is still in the appropriate position, that is horizontally centered and vertically 1/3 from the bottom inside the window. (When the drum is empty).

Lubricate the bearings after every 200 hours of operation or replace the automatic lubricator annually.

**Annual maintenance**

Belt tension:

Verify that the belts are running in the middle of the basket pulley.  
 Verify the belt tension according to the table below. Belt tension measurements should be taken as close as possible to the center of the belt span (see figure).

Belt tension testing table								
Model	Belt	Frequency (Hz)		Tension force (N)		Deflection (mm)		Deflection force MAX
		MIN	MAX	MIN	MAX	at MIN tension	at MAX tension	
455 (100)	3-XPA2360	42	45	400/belt	460/belt	17,5	16,2	50
575 (135)	3-XPA2360	42	45	400/belt	460/belt	17,5	16,2	50
730 (165)	4-XPA2800	42	48	502/belt	657/belt	16,8	13,8	50
900	4-XPA2800	42	48	502/belt	657/belt	16,8	13,8	50

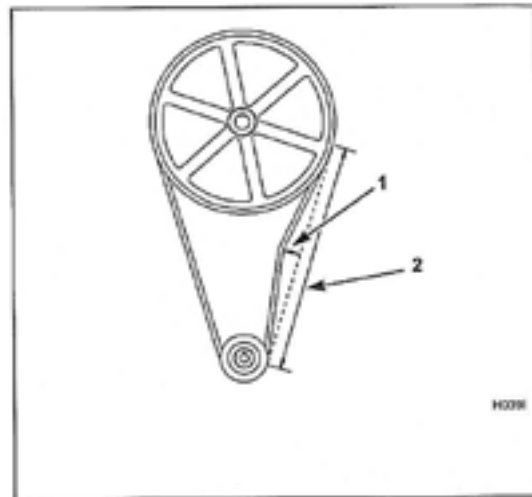

- 1 Deflection
- 2 Span length

**Contact Information**

**Nameplate**

**Nameplate Location**

The nameplate is located at the rear of the machine. Always provide the machine's serial number and model number when ordering parts or when seeking technical assistance. See Labels 17 and 18.

Type:	HF575P	Nr:	07110580147
Voltage:	3 - 380V 50Hz	Weight:	1787 kg
Motor:	7,5 kW 20 A	Capacity:	575 L
Heating:	36 kW 60 A	Dry load:	57 Kg
Total:	43,50 kW	Drum:	980 mm
Kinetic energy:	23257N/M	Speed:	800 rpm
Manufactured in:	2007		
Water pressure:		min. 2,07 max. 5,86 Kg/cm <sup>2</sup> min. 20,7 max. 58,6 N/cm <sup>2</sup>	IPX4
s/c: 741295			
Alliance International BVBA			
			
Nieuwstraat 148			
8500 Wavolgem			
Belgium			
Tel: +32 58 41 20 54			
Fax: +32 58 41 86 74			
www.ipso.be			

Label 17

Model No:	UX165PVQU70001	Serial No:	0710740113
Volts/Hertz:	208-240/50/60	Type:	HF730P
Phase:	3	Capacity:	165/73 lbs/kg
Amps:	20 amps	Water Pressure:	30-85 psi 2.07-5.86 bar
Recommended Circuit Breaker:	25 amps	Max Speed:	750 rpm
Interrupt Current:	10 kA	Net Weight:	3520 lbs 5070 kg
Motor:	15 hp 11 kW	Elec Heat:	N/A kW
Steam heat:	N/A psi N/A bar		IPX4
Alliance International BVBA Made in Belgium		 CONFORMS TO ANSI/UL STD 2157 CERTIFIED TO CANICSA STD C22.2 NO.169	
			
TEL 1-920-748-3121 www.comlaundry.com			

Label 18

Position of the Serial plate

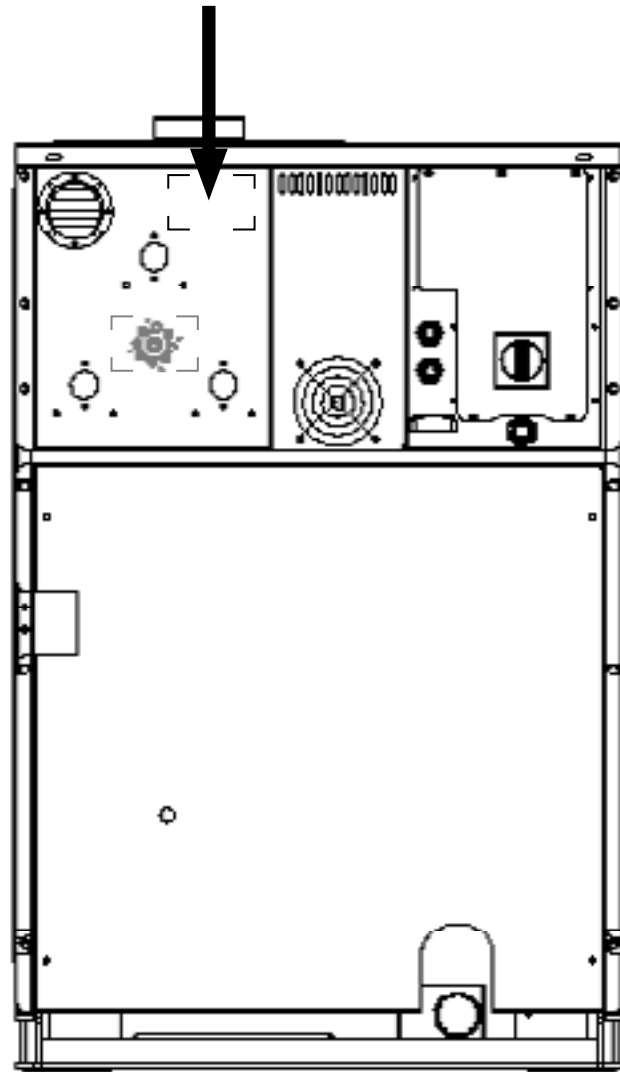

**Replacement Parts**

If literature or replacement parts are required, contact the source from which the machine was purchased or contact the phone numbers or websites shown on the nameplate.

In case of important malfunctions and deficiencies, which you cannot resolve yourself, contact your distributor.

**Distributor :** Name:.....  
 Address: .....  
 Tel.:.....

**Machine :** Type:.....  
 Program:.....  
 Date of installation: .....  
 Installed by: .....  
 Serial number: .....  
 Operation voltage and frequency: .....

Alliance Laundry Systems  
 Shephard Street, PO BOX 990  
 Ripon, WI 54971-0990  
 United States  
 Tel: 001 920 748 3121 - Fax: 001 920 748 1645  
 www.comlaundry.com

Alliance International bvba  
 Nieuwstraat 146 - B-8560 Wevelgem (Belgium)  
 Tel. +32 56 41 20 54 - Fax +32 56 41 86 74  
 info@alliances.eu - www.alliances.eu

